



N510 Series

USER MANUAL Box Operations

- Before using this Product, please read the USER MANUAL carefully and keep it for your reference.

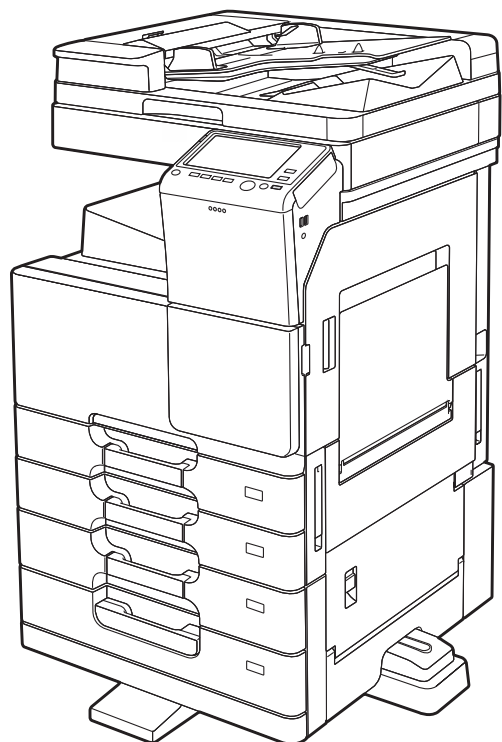



Table of contents

1 About the Boxes

1.1	Box Screen	1-2
1.2	Available Operations with User Box	1-3
1.3	Available operations with System Box	1-4
	[Secure Print]	1-4
	[Memory RX]	1-4
	[ID & Print].....	1-5
	[Bulletin Board].....	1-5
	[Polling TX]	1-6
	[Annotation].....	1-6
	[File Re-TX]	1-7
	[Password Encrypted PDF].....	1-7
	[External Memory].....	1-8
	[Relay User Box]	1-8
1.4	Number of Documents and Pages That Can Be Stored in the Boxes	1-9

2 Store Documents as Files in MFP and Use Them Again When Necessary

2.1	Boxes for Document Storage and Readout (User Box)	2-2
	Available operations with User Box	2-2
	Type of User Boxes.....	2-2
	User types that can access User Boxes.....	2-3
2.2	Rules to Use User Boxes	2-4
	Public User Box	2-4
	Personal User Box	2-5
	Group User Box	2-6
	When using a combination of Personal User Box and Group User Box	2-7
2.3	Create User Box	2-8
2.4	Save File in a User Box	2-9
	Save (basic operation flow)	2-9
	Save files in Copy mode.....	2-10
	Save file in Fax/Scan mode.....	2-10
	Save files from a PC	2-10
	Save file from a USB memory	2-10
2.5	Print File in a User Box	2-11
	Print (basic operation flow)	2-11
	Print multiple files at the same time (Combine)	2-12
2.6	Send Files in a User Box	2-15
2.6.1	Sending (Basic Operation Flow).....	2-15
2.6.2	Set a Destination.....	2-16
	Selecting from address book.....	2-16
	Searching for destinations.....	2-17
	Direct input.....	2-18
	Selecting from the history.....	2-19
	Search for mail address or fax number from the LDAP server	2-19
2.6.3	Send Multiple Files at the Same Time (Combine TX).....	2-19
2.6.4	Specify the Destination (for Combine TX).....	2-21
	Selecting from address book.....	2-21
	Searching for destinations.....	2-22
	Direct input.....	2-23
	Select file from the history	2-23
	Searching for an E-mail address through the LDAP server	2-24
2.7	Organize Files in a User Box	2-25
	Operation flow	2-25
	Delete a file	2-26
	Rename a file.....	2-26



	Move file to another User Box	2-26
	Copy file to another User Box	2-27
	Edit a page	2-27
	Save file in a USB memory	2-28
	Store file as an overlay image	2-29
	Re-create a file in an SMB sharing	2-30
	Check the file information	2-30
2.8	Operate a User Box from the PC.....	2-32
2.8.1	Operate a User Box via Web Connection.....	2-32
	Open User Box	2-32
	Printing a file in a User Box.....	2-32
	Send files in a User Box.....	2-33
	Download files in a User Box to the PC.....	2-34
	Move or copy files in a User Box to another User Box	2-35
	Delete files from a User Box.....	2-36
2.8.2	Operate a User Box using the Box Operator.....	2-37
2.9	Sharing files in the Public User Box on the Network (Share SMB File)	2-38
	Share SMB File.....	2-38
	Operations required to use this function (For administrators)	2-38
	Saving files in the Public User Box	2-38
	Referencing files in the Public User Box through the computer	2-39

3 Receive Fax in Memory and Print It Later ([Memory RX])

3.1	[Memory RX].....	3-2
3.2	Print Fax in a User Box	3-3
3.3	Send Fax in a User Box.....	3-4
3.3.1	Sending (basic operation flow)	3-4
3.3.2	Set a Destination.....	3-5
	Selecting from address book	3-5
	Searching for destinations	3-6
	Direct input.....	3-6
	Select file from the history	3-7
	Searching for an E-mail address through the LDAP server	3-7
3.4	Organize Faxes in a User Box.....	3-9
	Operation flow	3-9
	Delete a file	3-10
	Rename a file.....	3-10
	Check the file information.....	3-10

4 Retransmit Fax If Redialing Has Failed ([File Re-TX])

4.1	[File Re-TX].....	4-2
4.2	Send Fax in a User Box.....	4-3
4.2.1	Sending (Basic Operation Flow).....	4-3
4.2.2	Set a Destination.....	4-4
	Selecting from address book	4-5
	Searching for destinations	4-5
	Direct input.....	4-6
	Selecting from the history.....	4-6
	Searching for a fax number from the LDAP server	4-6
4.3	Print Fax in a User Box	4-7
4.4	Organize Faxes in a User Box.....	4-9
	Operation flow	4-9
	Delete a file	4-10
	Check the file information.....	4-10

5 Print Classified Documents ([Secure Print])



5.1	[Secure Print]	5-2
5.2	Print Files in a User Box	5-3
	Print (basic operation flow)	5-3
	Print (If [Prohibited Functions When Authentication Error] is set to [Mode 2])	5-4
5.3	Organize Files in a User Box	5-7
	Operation flow	5-7
	Delete a file	5-8
	Rename a file	5-8
	Check the file information	5-8

6 Annotate Files ([Annotation])

6.1	[Annotation]	6-2
6.2	Create an Annotation User Box	6-3
6.3	Save File in a User Box	6-4
	Save (basic operation flow)	6-4
	Save files in Copy mode	6-5
	Save files from a PC	6-5
6.4	Print Files in a User Box	6-6
6.5	Send Files in a User Box	6-8
6.5.1	Sending (Basic Operation Flow)	6-8
6.5.2	Set a Destination	6-10
	Selecting from address book	6-10
	Searching for destinations	6-10
	Direct input	6-11
	Select file from the history	6-11
	Searching for an E-mail address through the LDAP server	6-12
6.6	Organize Files in a User Box	6-13
	Operation flow	6-13
	Delete a file	6-14
	Rename a file	6-14
	Store file as an overlay image	6-14
	Check the file information	6-15

7 Print an Encrypted PDF ([Password Encrypted PDF])

7.1	[Password Encrypted PDF]	7-2
7.2	Store File in User Box, or Print File from User Box	7-3
7.3	Organize Files in a User Box	7-4
	Operation flow	7-4
	Delete a file	7-5
	Check the file information	7-5

8 Registering a File for Polling ([Polling TX])

8.1	[Polling TX]	8-2
8.2	Print Files in a User Box	8-3
8.3	Organize Files in a User Box	8-4
	Operation flow	8-4
	Delete a file	8-5
	Store file as an overlay image	8-5
	Check the file information	8-6

9 Store File for Polling ([Bulletin])

9.1	[Bulletin]	9-2
9.2	Create Bulletin Board User Box	9-3
9.3	Print Files in a User Box	9-4
9.4	Organize Files in a User Box	9-6



Operation flow	9-6
Delete a file	9-7
Check the file information.....	9-7

10 Use as Fax Transponder ([Relay User Box])

10.1	[Relay User Box]	10-2
10.2	Operations Required to Use This Function	10-3
	Register the fax recipients.....	10-3
	Create a Relay User Box.....	10-3

11 Print on MFP under Authentication Control ([ID & Print])

11.1	[ID & Print]	11-2
11.2	Print Files in a User Box	11-3
11.3	Organize Files in a User Box.....	11-5
	Operation flow	11-5
	Delete a file	11-6
	Check the file information.....	11-6

12 Use a USB Memory Device ([External Memory])

12.1	[External Memory].....	12-2
12.2	Supported USB Memory Devices	12-3
12.3	Print a File from a USB Memory Device	12-4
	Operations required to use this function (for the administrator)	12-4
	Operation flow	12-4
12.4	Save Scanned Data on a USB Memory.....	12-6
	Preparation required to use this function (for the administrator)	12-6
	Operation flow	12-6
12.5	Store USB Memory Files in External Memory User Box	12-8
	Preparation required to use this function (for the administrator)	12-8
	Operation flow	12-8

13 Appendix

13.1	Optional Settings before File Storage.....	13-2
	Changing a file name ([File Name])	13-2
	Scanning a 2-sided original ([Simplex/Duplex])	13-2
	Specifying the resolution to scan the original ([Resolution])	13-3
	Selecting the color mode to scan the original ([Color])	13-3
	Specifying the file type used to save the scanned original data ([File Type]).....	13-4
	Specifying the original size for scanning ([Scan Size])	13-5
	Scanning originals of varying sizes in a batch ([Mixed Original])	13-6
	Scanning an original thinner than normal paper ([Thin Paper Original])	13-6
	Scanning a folded original ([Z-Folded Original])	13-6
	Scanning a long original ([Long Original]).....	13-7
	Specifying the original loading direction ([Original Direction])	13-7
	Specifying the original binding position ([Binding Position])	13-7
	Scanning while removing dust in the slit glass ([Despeckle]).....	13-8
	Skipping blank pages ([Blank Page Removal])	13-8
	Splitting the left and right pages of a book and catalog ([Book Original]).....	13-8
	Scanning a number of originals in several batches ([Separate Scan])	13-9
	Selecting the appropriate image quality for the contents of the original ([Original Type])	13-10
	Adjusting the density to scan the original ([Density])	13-11
	Adjusting the background density of the original to be scanned ([Bkgd. Removal]).....	13-11
	Scanning after erasing text and shadows in the margins of an original ([Frame Erase])	13-11
	Sharpen the boarder between text etc. ([Sharpness])	13-12

13.2	Optional Settings before Printing	13-13
	Enlarge or reduce an image ([Zoom])	13-13
	Specifying paper ([Paper])	13-13
	Printing on both sides of paper ([Simplex/Duplex])	13-13
	Printing multiple pages on the same side of a single sheet ([Combine])	13-14
	Stapled sheets ([Staple])	13-14
	Punching the printed sheets ([Punch])	13-15
	Folding/Biding ([Fold/Bind])	13-15
	Outputting by sets ([Group/Sort])	13-16
	Outputting each set in staggered position ([Offset])	13-16
	Printing a sheet or book ([Sheet/Book Print])	13-17
	Printing multiple pages in a PDF file, XPS file, or OOXML format file on the same side of a single sheet ([Combination])	13-17
	Printing in a booklet format ([Booklet])	13-17
	Adding margin on pages ([Page Margin])	13-18
	Fine-tuning the print position ([Image Shift])	13-19
	Inserting front and back covers ([Cover Sheet])	13-19
	Inserting a different sheet into the specified page ([Insert Sheet])	13-20
	Arrange the first page of the chapter on the front side ([Chapters])	13-20
	Adding the date and time ([Date/Time])	13-21
	Adding the page number ([Page Number])	13-22
	Adding a stamp ([Stamp])	13-23
	Adding the stamp on the entire page ([Stamp Repeat])	13-23
	Adding information to the header/footer ([Header/Footer])	13-24
	Composing stored images ([Registered Overlay])	13-24
	Printing a concealed security watermark ([Copy Protect])	13-25
13.3	Optional Settings before File Transfer	13-26
	Change the file resolution ([Resolution])	13-26
	Change the file color ([Color])	13-26
	Change a file type ([File Type])	13-27
	Changing a file or a subject ([File Name/Subject Name/Other])	13-28
	Adding the date and time ([Date/Time])	13-29
	Adding the page number ([Page Number])	13-29
	Adding a stamp ([Stamp])	13-30
	Adding information to the header/footer ([Header/Footer])	13-31
	Sending and printing at the same time ([Save & Print])	13-31
	Changing a character string to be printed ([Stamp Settings])	13-32
	Report the destination of transfer file ([URL Dest. Settings])	13-32
	Encrypt an e-mail ([Mail Encryption])	13-32
	Add digital signature to e-mails ([Digital Signature])	13-32
	Sending by renaming the sender ([Fax Header Settings])	13-32
	Set a fax line type ([Line Setting])	13-33
	Sending a fax at preset time ([Timer TX])	13-33
	Sending a fax with a password ([Password TX])	13-34
	Sending a fax after specifying a F-code ([F-Code TX])	13-34





About the Boxes

1 About the Boxes

1.1 Box Screen

The Box screen displays the User Box and the System Box.

The user can store documents in the User Box. Also, the user can print a file from the User Box or send a file to another user.

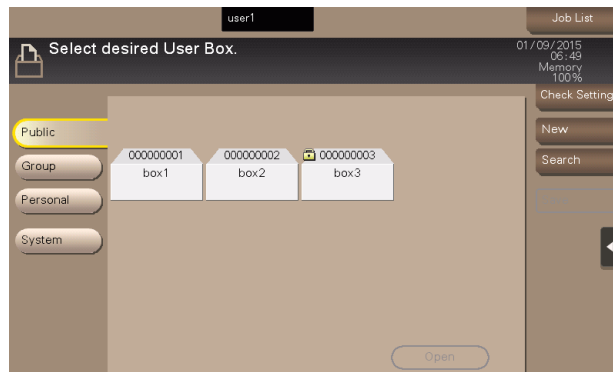

The System Box is used by the system to temporarily store files when the user uses the facsimile or print function together with the file storage function of the box.

The user can operate files in the System Box when necessary.

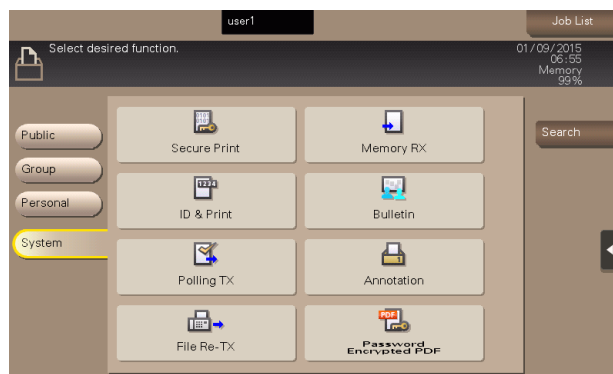

Tips

- The **Hard Disk** is optional in some areas. To use the User Box function, the optional **Hard Disk** must be installed in this machine.

1.2 Available Operations with User Box

The User Box is a box in which the user can store documents and use them again when necessary.

The original data read by this machine can be converted into a file and stored in the User Box. Also, data can be stored in the User Box when printing is specified by any PC running on the network. A file stored in the User Box can be printed out or sent out to another user.

If the frequently used original data is stored in the User Box, you do not need to search for the document or data when they are being printed or sent. Because you do not need to operate the printer from a PC, you can reduce operation time and improve the efficiency with which you carry out tasks.

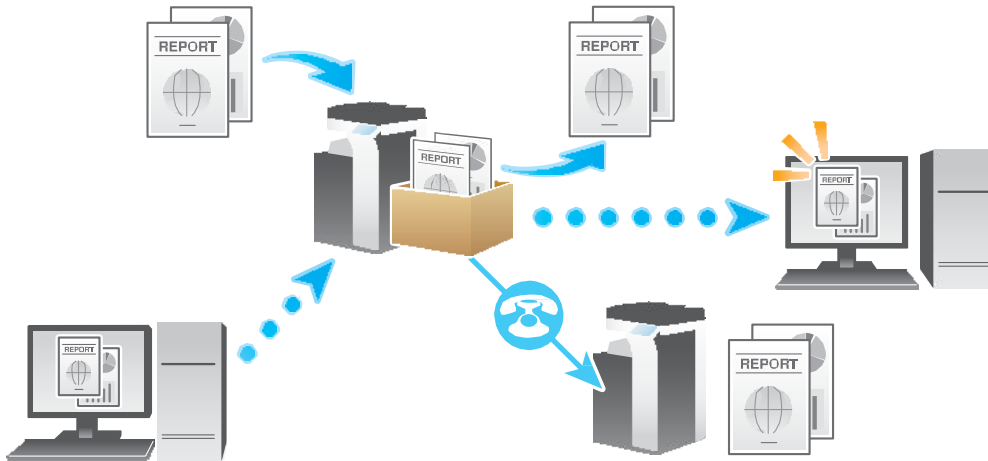

The following types of User Boxes are available.

Type	Description
[Public]	<p>This is the public box in which all users can store documents and use them. A password can be set for each box in order to control access to it.</p> <p>If documents are created in an electronic format and stored in the Public User Box, all users can share the same information by accessing this box. Also, users do not need to search for documents or data or operate the printer during printing. This will save the user time and improve the efficiency with which they carry out tasks.</p> <p>Using the Share SMB File function allows you to share files in the Public User Box on the network.</p>
[Personal]	<p>This is a personal box and if user authentication is implemented, only users who have logged in to the system can store documents in the Personal User Box and use documents contained in it when necessary. Because this box is not displayed to other users, there is no chance that important files will be erroneously deleted from the box.</p> <p>If frequently used documents are created in an electronic format and stored in the Personal User Box, users do not need to search for documents or data or operate the printer from a PC during printing. This will save the user time and improve the efficiency with which they carry out tasks.</p>
[Group]	<p>This is a user box. If the Account Track is implemented, only users belonging to the same department (or group) can store and use documents in the Group User Box. This box is not displayed when a user of another department or a public user have logged in.</p> <p>If documents are stored in the Group User Box, all users of each group can share the same information by accessing this box.</p>

Tips

- The **Hard Disk** is optional in some areas. To use this function, the optional **Hard Disk** must be installed in this machine.

1.3 Available operations with System Box

[Secure Print]

When you print a document from the PC or when you select the Secure Print function using the printer driver, this data file is stored in the Secure Print User Box. Once you have opened the User Box, you can select a file stored in the User Box and preview, print, rename, or delete it.

The document ID and password are required to print out the files stored in the Secure Print User Box. After the file has been printed out, it is deleted automatically. This box is used to handle classified documents.

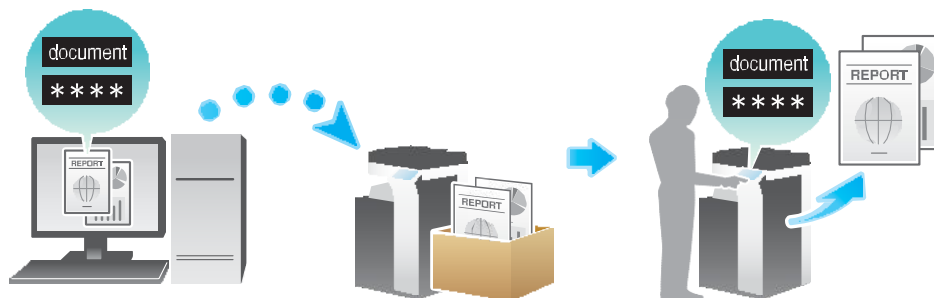

Tips

- The **Hard Disk** is optional in some areas. To use this function, the optional **Hard Disk** must be installed in this machine.

[Memory RX]

When a facsimile is received by the Memory RX function, it is stored in the Memory RX User Box. Once you have opened the User Box, you can select a fax stored in the User Box and preview, print, send, rename, or delete it.

Because the received faxes are forcibly stored in this box, you can print out only the required faxes and subsequently reduce total printing costs. Also, this will prevent important faxes from being stolen or lost and therefore enhance security.

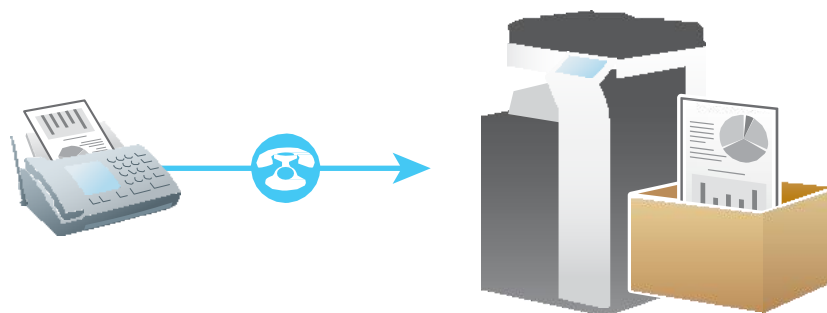

Tips

- The **Hard Disk** is optional in some areas. To use this function, install the optional **Hard Disk** and **FAX Kit** in this machine or enable the Internet Fax function. Internet Fax must be configured by your service representative. For details, contact your service representative.

[ID & Print]

When you print a document from the PC in the user authentication system environment, the files transferred with the ID & Print function are stored in the ID & Print User Box. When a user who has sent the print data logs in to this machine and opens the User Box, he/she can preview, print out, or delete the stored file.

Because user authentication is required in order to use a file, this box is useful for handling documents containing private information.

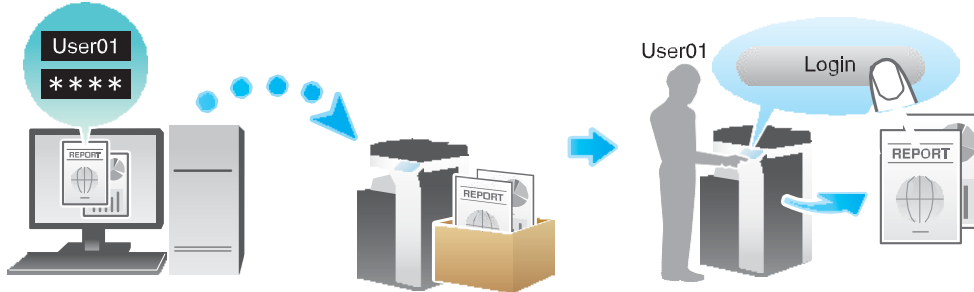

Tips

- The **Hard Disk** is optional in some areas. To use this function, the optional **Hard Disk** must be installed in this machine.

[Bulletin Board]

Multiple fax documents required for polling can be stored in the Bulletin Board User Box.

You can create and register up to 10 Bulletin Board User Boxes. Once you have opened the User Box, you can select a fax document stored in the User Box and preview, print out, or delete it.

If announcement and other fax documents are stored in Bulletin Board User Boxes by purpose and if recipients are notified with the relating box numbers, the users can select the required fax documents and they can be polled.

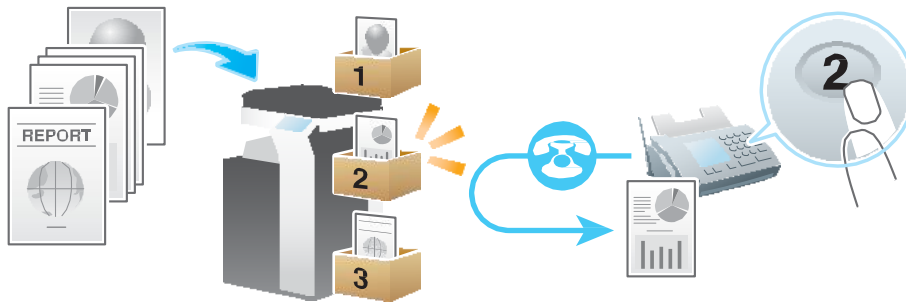

Tips

- The **Hard Disk** is optional in some areas. To use this function, the optional **Hard Disk** and **Fax Kit** must be installed in this machine.

[Polling TX]

The fax documents required for polling are stored in the Polling Transmission User Box. Once you have opened the User Box, you can select a fax document stored in the User Box and preview, print out, or delete it.

If the fax documents are stored in the Polling TX User Box, recipients can be polled and receive fax documents from this box when necessary.

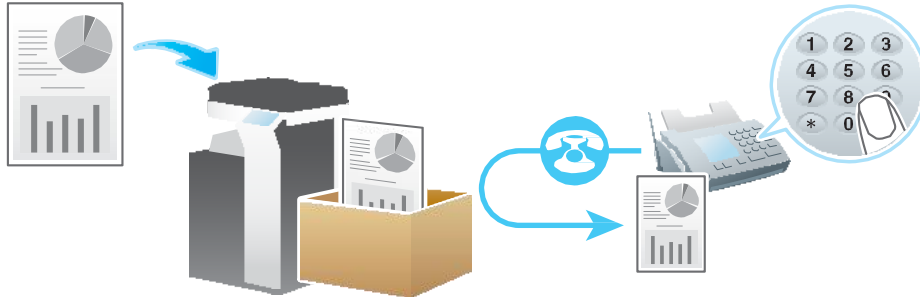

Tips

- The **Hard Disk** is optional in some areas. To use this function, the optional **Hard Disk** and **Fax Kit** must be installed in this machine.

[Annotation]

When a stored file is printed out or sent to another user, its date, time and any annotations are added to this box automatically. Once you have opened the User Box, you can select a file stored in the User Box and preview, print out, send, rename, or delete it.

When a file is read from the Annotation User Box and used for printouts or transmitted to a recipient, the date, time and any annotations (previously determined for management) are automatically added to the header or footer of each image. You can prevent the unauthorized use of documents by creating a document that can identify the creation date and time and serial page number of each document.

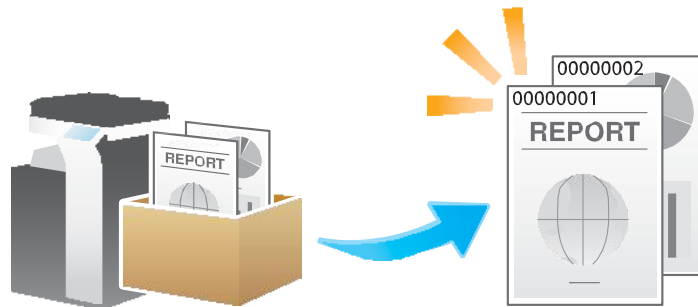

Tips

- This function is available when the Web browser function is disabled. When the optional **Extension Memory** is installed, this function is available regardless of whether the Web browser function is enabled or disabled.
- The **Hard Disk** is optional in some areas. To use this function, the optional **Hard Disk** must be installed in this machine.

[File Re-TX]

When the recipient is busy and if communication cannot be established, undeliverable fax documents are stored in the Fax Retransmit User Box. Once you have opened the User Box, you can select a fax document stored in the User Box and preview, print out, send, or delete it.

Fax transmission is attempted for the number of times set by Auto Redialing function. If those attempts have failed, the fax document is stored in the Fax Retransmit User Box.

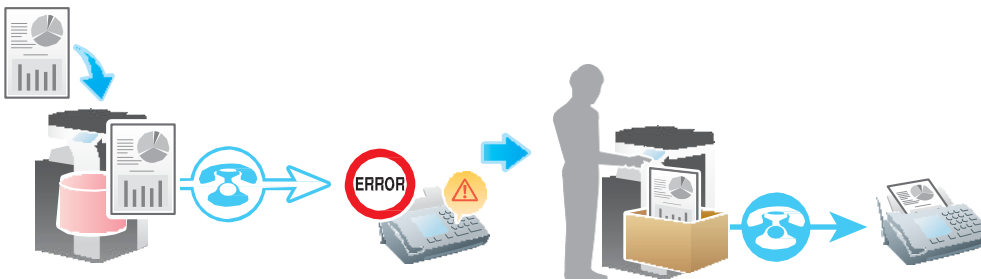

Tips

- The **Hard Disk** is optional in some areas. To use this function, the optional **Hard Disk** and **Fax Kit** must be installed in this machine.

[Password Encrypted PDF]

When a password protected PDF file is printed out or stored in the User Box by using the Direct Print function or from USB memory, the file is stored in the Password Encrypted PDF User Box. Once you have opened the User Box, you can select a PDF file stored in the User Box to preview and print it out. Also, you can store the file in or delete it from the User Box.

When printing or saving a PDF file, you will need to enter a password that was set for the file.



Tips

- The **Hard Disk** is optional in some areas. To use this function, the optional **Hard Disk** must be installed in this machine.

[External Memory]

This window appears when you insert a USB memory device into the USB port of this machine.

Once you have opened the User Box, you can print out a file stored on a USB memory. Also, you can read the original data and directly save it as a file in the USB memory. You can also move a file from the USB memory to the External Memory User Box.

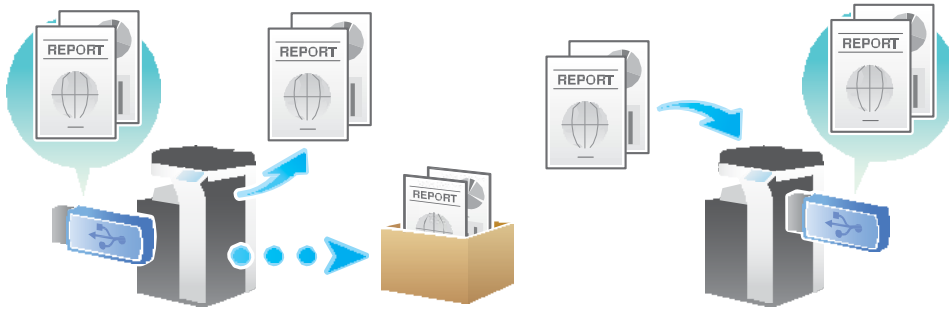

Tips

- The **Hard Disk** is optional in some areas. To use this function, the optional **Hard Disk** must be installed in this machine.

[Relay User Box]

When you use this machine as a relay machine to the facsimile, the Relay User Box is used for data relay.

If you use the Relay Distribution and when you send a fax to the relay machine, it distributes the fax to all recipients being registered in the Relay User Box.

If you are using broadcasting to distant places, you can reduce the total communication cost by using the relay machine.

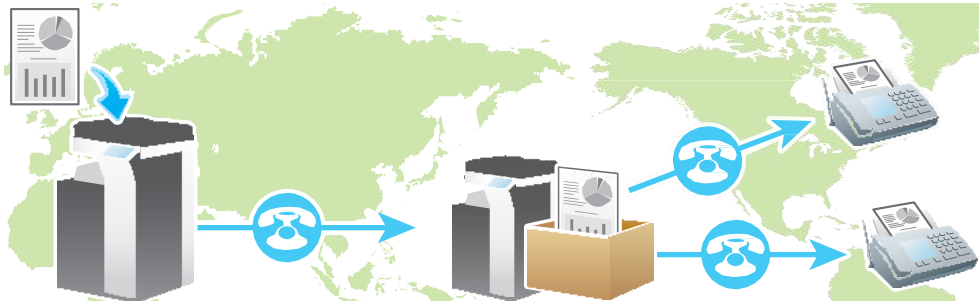

Tips

- The **Hard Disk** is optional in some areas. To use this function, the optional **Hard Disk** and **Fax Kit** must be installed in this machine.

1.4 Number of Documents and Pages That Can Be Stored in the Boxes

The number of documents and pages that can be stored in the boxes is as follows.

- For User Boxes and System Boxes, one box can store up to 200 documents. However, the Memory RX User Box can store up to 500 documents.
- The User Boxes and System Boxes can store up to a total of 3000 documents.
- The User Boxes and Systems Boxes can store up to a total of 10000 pages.



**Store Documents as Files in
MFP and Use Them Again
When Necessary**

2 Store Documents as Files in MFP and Use Them Again When Necessary

2.1 Boxes for Document Storage and Readout (User Box)

Available operations with User Box

This machine allows a user to create a User Box where the user can store documents and use them again when necessary. This box is called the User Box.

The original data scanned by this machine can be converted into a file and stored in the User Box. Also, data can be stored in the User Box when printing is specified by any PC running on the network. A file stored in the User Box can be printed out or sent out to another user.

If the frequently used original data is stored in the User Box, you do not need to search for the document or data when they are being printed or sent. Because you do not need to operate the printer from a PC, you can reduce operation time and improve the efficiency with which you carry out tasks.

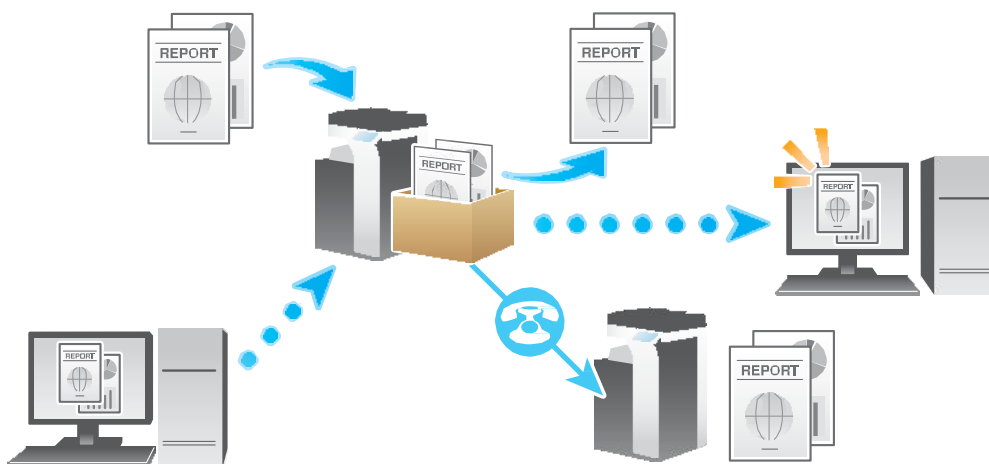

Tips

- The **Hard Disk** is optional in some areas. To use this function, the optional **Hard Disk** must be installed in this machine.

Type of User Boxes

This section explains how to use the following User Boxes.

Type	Description
[Public]	<p>This is the public box in which all users can store documents and use them. A password can be set for each box in order to control access to it.</p> <p>If documents are created in an electronic format and stored in the Public User Box, all staff can share the same information by accessing this box. Also, users do not need to search for documents or data or operate the printer during printing. This will save the user time and improve the efficiency with which they carry out tasks.</p> <p>Using the Share SMB File function allows you to share files in the Public User Box on the network.</p>

Type	Description
[Personal]	<p>This is a personal box and if user authentication is implemented, only users who have logged in to the system can store documents in the Personal User Box and use documents contained in it when necessary. Because this box is not displayed to other users, there is no chance that important files will be erroneously deleted from the box.</p> <p>If frequently used documents are created in an electronic format and stored in the Personal User Box, users do not need to search for documents or data or operate the printer from a PC during printing. This will save the user time and improve the efficiency with which they carry out tasks.</p>
[Group]	<p>This is a user box. If the Account Track is implemented, only users belonging to the same department (or group) can store and use documents in the Group User Box. This box is not displayed when a user of another department or a public user have logged in.</p> <p>If documents are stored in the Group User Box, all users of each group can share the same information by accessing this box.</p>

User types that can access User Boxes

Accessible User Boxes vary depending on the user type. This machine provides the following user types.

Item	Description
Registered user	Refers to a user registered on this machine with user authentication implemented.
Public user	Refers to a user who is not registered on this machine with user authentication implemented. Some functions are restricted depending on settings.
Administrator	Administrator who manages this machine. The administrator can create, change, or delete all User Boxes regardless of whether the password is specified.
User Box administrator	If the administrator of this machine wants to entrust only box file management to another person, this administrator can assign a box administrator (Default: [Restrict]). A User Box administrator can access all User Boxes and System User Boxes. For details, refer to "User's Guide[Descriptions of Functions/Utility Keys]/[Utility]".

2.2 Rules to Use User Boxes

Public User Box

All users can reference to User Boxes.

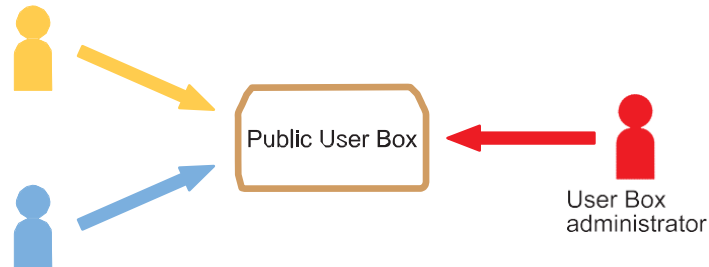

User Box operations vary depending on user types. The following shows what different operations are available depending on user types.

User type	Available operations
Registered user Public user User Box administrator*	Check, download, or delete a document in a User Box Create a User Box Change User Box settings Delete a User Box
Administrator*	Create a User Box Change User Box settings Delete a User Box

* An administrator and User Box administrator can operate password protected User Boxes without having to enter a password.



Related setting (for the administrator)

- The administrator can set an authority so that each user is allowed to create, edit, or delete a User Box (default: [Allow]). For details, refer to "User's Guide[Descriptions of Functions/Utility Keys]/[Utility]".

Personal User Box

If User Authentication has been implemented, a user can only access the Personal User Box the user has created. Other users cannot access this box.

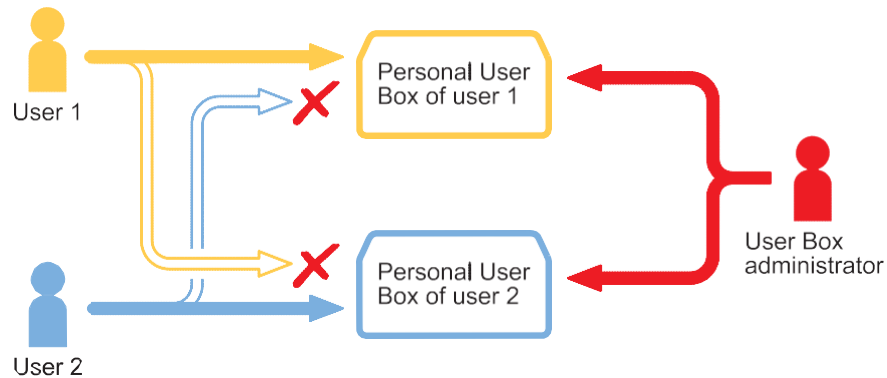

User Box operations vary depending on user types. The following shows what different operations are available depending on user types.

User type	Available operations
Public user	Cannot create and use a Personal User Box.
Registered user ^{*1} User Box administrator ^{*2}	Check, download, or delete a document in a User Box Create a User Box Change User Box settings Delete a User Box
Administrator ^{*2}	Create a User Box Change User Box settings Delete a User Box

^{*1} This user can operate only User Boxes created by a registered user.

^{*2} An administrator and User Box administrator can operate password protected User Boxes without having to enter a password.

Tips

- When releasing the User Authentication or when changing the authentication system and deleting the authentication data, the administrator can change the Personal User Box to a Public User Box or can delete the Personal User Box.

Group User Box

If Account Track has been implemented, a user can only access the Group User Box of the department the user belongs to. A user of another department cannot access this box.

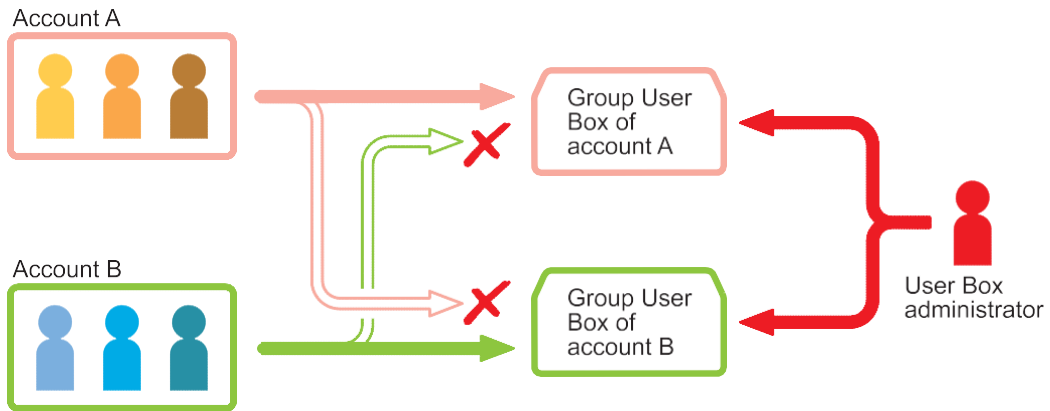

User Box operations vary depending on user types. The following shows what different operations are available depending on user types.

User type	Available operations
Public user	Cannot create and use a Group User Box.
Registered account ^{*1} User Box administrator ^{*2}	Check, download, or delete a document in a User Box Create a User Box Change User Box settings Delete a User Box
Administrator ^{*2}	Create a User Box Change User Box settings Delete a User Box

^{*1} Only the User Box created by the user in the same account track can be operated.

^{*2} An administrator and User Box administrator can operate password protected User Boxes without having to enter a password.

Tips

- When releasing the User Authentication or when changing the authentication system and deleting the authentication data, the administrator can change the Group User Box to a Public User Box or can delete the Group User Box.

When using a combination of Personal User Box and Group User Box

If both User Authentication and Account Track have been implemented, a user can access to the Public User Box, a Personal User Box created by the user himself or herself, and the Group User Box of the department the user belongs to.

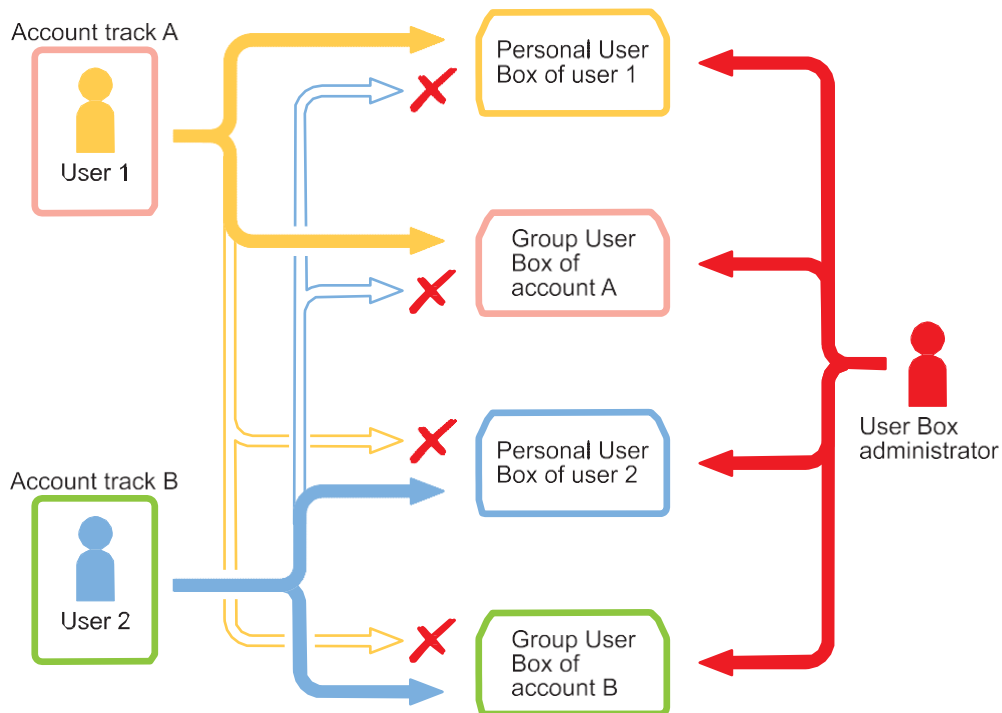

Tips

- The Personal User Box is inaccessible by another user.
- If user authentication and department management are not linked to each other, the user can access a Group User Box of his/her department when the user enters the correct department name and password in the authentication field of Group User Box during login.
- When releasing the User Authentication or when changing the authentication system and deleting the authentication data, the administrator can change both Personal User Box and Group User Box to Public User Boxes or can delete the Personal and Group User Boxes.

2.3 Create User Box

Up to 1000 User Boxes can be created.

- 1 Tap [Utility] - [One-Touch/User Box Registration] - [Create User Box] - [Public/Personal User Box] - [New].
→ The administrator can perform the same actions by selecting [Administrator Settings] - [One-Touch/User Box Registration].

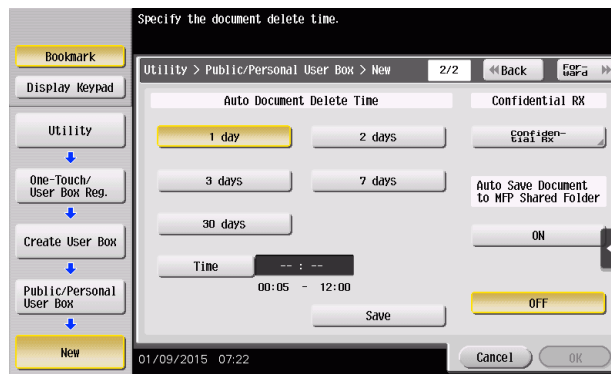
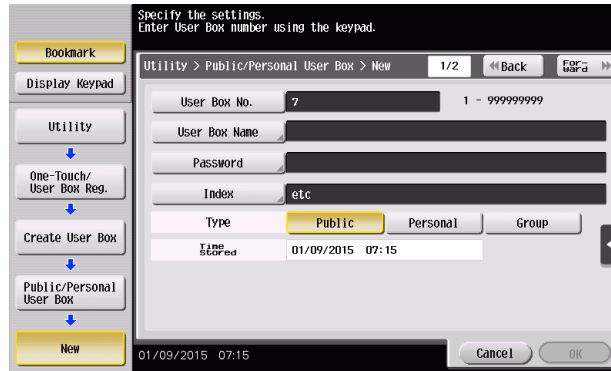

- 2 Enter the registration information, then tap [OK].
→ For details on registration information, refer to "User's Guide[Descriptions of Functions/Utility Keys]/[Utility]".

Related setting (for the administrator)

- The administrator can delete all unused and empty boxes simultaneously. For details, refer to "User's Guide[Descriptions of Functions/Utility Keys]/[Utility]".
- The administrator can select an authority so that each user is allowed to create, edit, or delete a User Box (default: [Allow]). For details, refer to "User's Guide[Descriptions of Functions/Utility Keys]/[Utility]".
- You can set a limit on the number of boxes that each user can create. For details, refer to "User's Guide[Descriptions of Functions/Utility Keys]/[Utility]".
- The administrator can set a time to automatically delete files from all User Boxes (Default: [No]). For details, refer to "User's Guide[Descriptions of Functions/Utility Keys]/[Utility]".

Reference

You can also register boxes using **Web Connection**. For details, refer to "User's Guide[Web Management Tool]/[Configuring the User Box Environment]".

Using the Share SMB File function allows you to share files in the Public User Box on the network. For details on the Share SMB File function, refer to page 2-38.

2.4 Save File in a User Box

Save (basic operation flow)

- 1 Load the original.

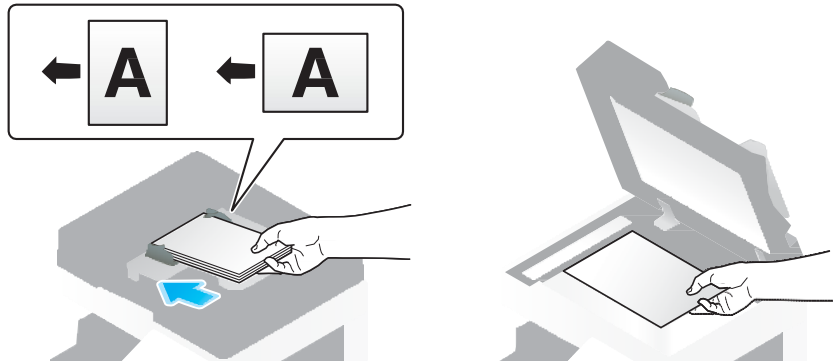

- 2 Tap [User Box].

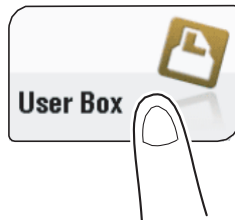

- 3 Select a User Box in which to save a file, then tap [Save].

- This example uses the Public User Box for explanatory purposes. To use a Personal User Box or a Group User Box, tap [Personal] or [Group] and select the desired box.
- Tap [New], to create a User Box. For details, refer to "User's Guide[Descriptions of Functions/Utility Keys]/[User Box]".
- To search for a User Box in which to save a file, tap [Search]. For details, refer to "User's Guide[Descriptions of Functions/Utility Keys]/[User Box]".

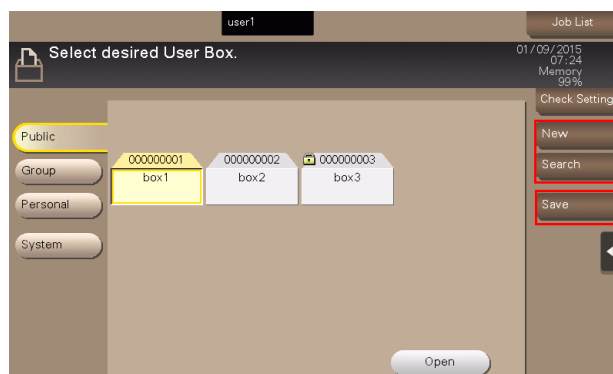

- 4 Set file save options if necessary.
→ For detailed optional settings, refer to page 13-2.

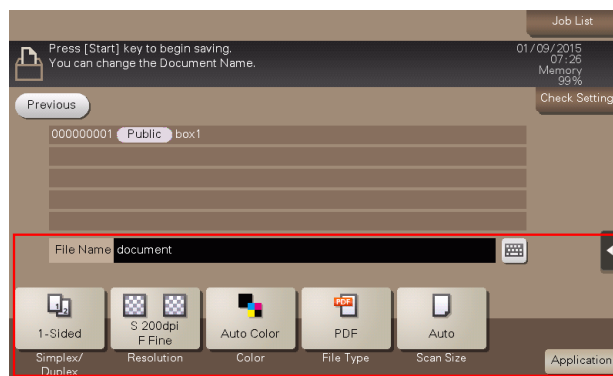

- 5 Press the **Start** key.
The file is saved.



Tips

- If files stored in a User Box are not used, they are deleted automatically when the [Auto Document Delete Time] has passed (Default: [1 day]).

Save files in Copy mode

You can read a document in Copy mode and save its data in the User Box.

For details, refer to "User's Guide[Copy Operations]/[Saving Original Images to a User Box]".

Save file in Fax/Scan mode

You can read the original data in Fax/Scan mode and save it in a User Box.

For details, refer to "User's Guide[Scan Operations]/[Saving a file in a User Box of this Machine (Save in User Box)]".

Save files from a PC

When specifying to print using the printer driver, you can specify a User Box number and store the print data in the box.

For details, refer to "User's Guide[Print Operations]/[Printing in the Windows Environment]".

Save file from a USB memory

You can save a file stored on a USB memory in a User Box.

For details, refer to page 12-8.

2.5 Print File in a User Box

Print (basic operation flow)

- 1 Tap [User Box].



- 2 Select the desired User Box, then tap [Open].

- This example uses the Public User Box for explanatory purposes. To use a Personal User Box or a Group User Box, tap [Personal] or [Group] and select the desired box.
- If the box is password protected, tap [Open] and enter the password.
- You can also open the desired User Box by tapping it twice.

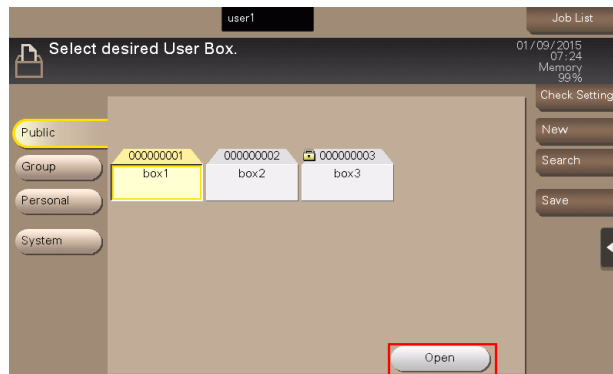

- 3 Select a file to print, then tap [Print].

- You can also long-tap the target file to display the menu icon, then drag and drop it to  to get the same result.

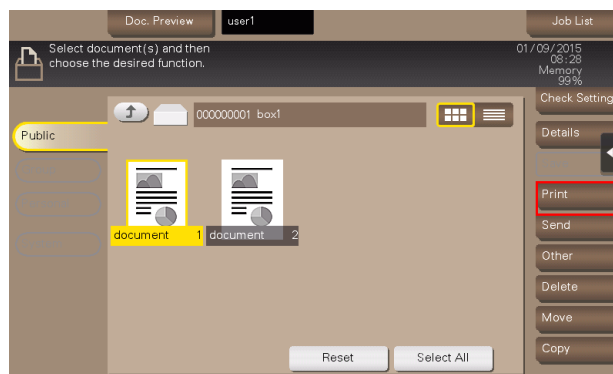

- 4 Set print options if necessary.
- If an output image cannot be displayed, [Preview on Screen] appears. To check an output image, tap [Preview on Screen], then confirm the target output image on the preview window.
 - For detailed optional settings, refer to page 13-13.

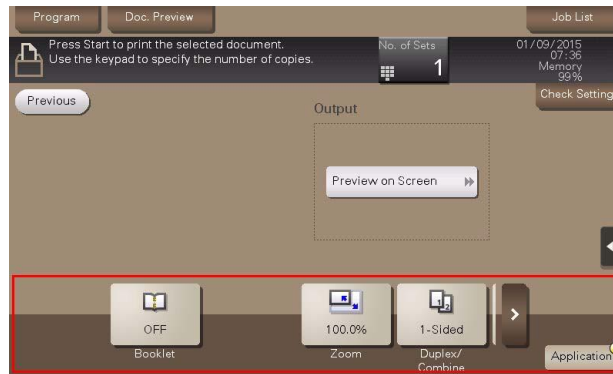

- 5 If necessary, enter the number of copies using the **Keypad**.
- Tapping [No. of Sets] displays the **Keypad**.
 - Pressing the **10 Keypad** key (default: Register key **3**) displays the **Keypad** on the **Touch Panel**, enabling you to enter numeric values.
 - To change the number of copies, tap [C] (Clear).
- 6 Press the **Start** key.
Printing starts.



Related setting (for the administrator)

- You can specify to hold or clear a file from the box after file printing or sending (Default: [Yes]). Also, you can prompt the user to hold or not hold a file in the box after it has been printed or sent in the delete confirmation screen. For details, refer to "User's Guide[Descriptions of Functions/Utility Keys]/[Utility]".

Print multiple files at the same time (Combine)

When printing multiple files at the same time, you can combine those files and handle them as a single job. This is called the Combine printing.

Using this function, you can reduce the print time and improve the efficiency as you can skip to repeat printing files one by one. You can collectively print up to 10 files.

- 1 Tap [User Box].

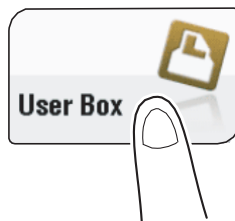

- 2 Select the desired User Box, then tap [Open].

- This example uses the Public User Box for explanatory purposes. To use a Personal User Box or a Group User Box, tap [Personal] or [Group] and select the desired box.
- If the box is password protected, tap [Open] and enter the password.
- You can also open the desired User Box by tapping it twice.

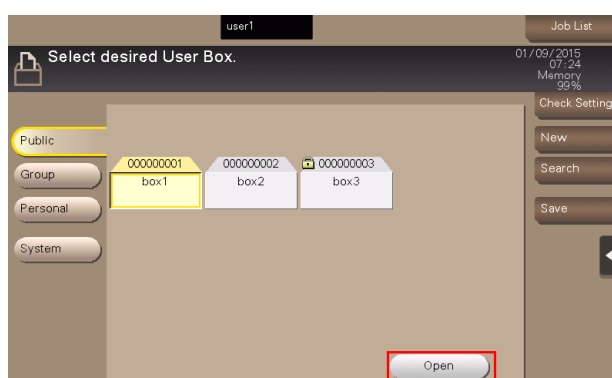

- 3 Select files for Combine printing, then tap [Other] - [Combine].

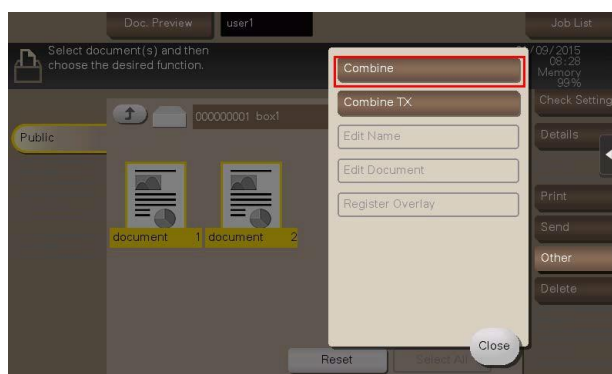

- 4 Change the order of printing files (Combine sequence) if necessary, then tap [OK].

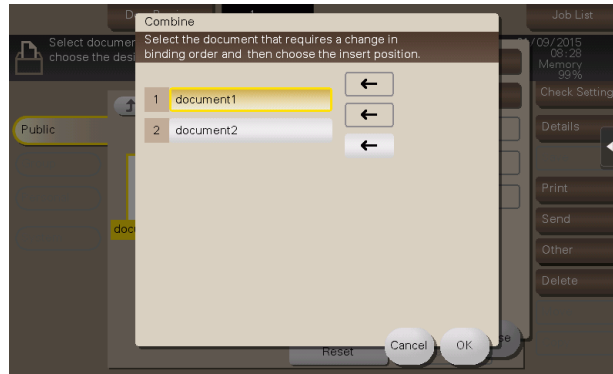

→ If you print a file containing a watermark first, the watermark will also be printed on the second and subsequent files.

- 5 Set print options if necessary.

→ If an output image cannot be displayed, [Preview on Screen] appears. To check an output image, tap [Preview on Screen], then confirm the target output image on the preview window.
→ For detailed optional settings, refer to page 13-13.

- 6 If necessary, enter the number of copies using the **Keypad**.

→ Tapping [No. of Sets] displays the **Keypad**.
→ Pressing the **10 Keypad** key (default: Register key **3**) displays the **Keypad** on the **Touch Panel**, enabling you to enter numeric values.
→ To change the number of copies, tap [C] (Clear).

- 7 Press the **Start** key.

Printing starts.



Related setting (for the administrator)

- You can specify to hold or clear a file from the box after file printing or sending (Default: [Yes]). Also, you can prompt the user to hold or not hold a file in the box after it has been printed or sent in the delete confirmation screen. For details, refer to "User's Guide[Descriptions of Functions/Utility Keys]/[Utility]".

2.6 Send Files in a User Box

2.6.1 Sending (Basic Operation Flow)

- 1 Tap [User Box].



- 2 Select the desired User Box, then tap [Open].
 - This example uses the Public User Box for explanatory purposes. To use a Personal User Box or a Group User Box, tap [Personal] or [Group] and select the desired box.
 - If the box is password protected, tap [Open] and enter the password.
 - You can also open the desired User Box by tapping it twice.

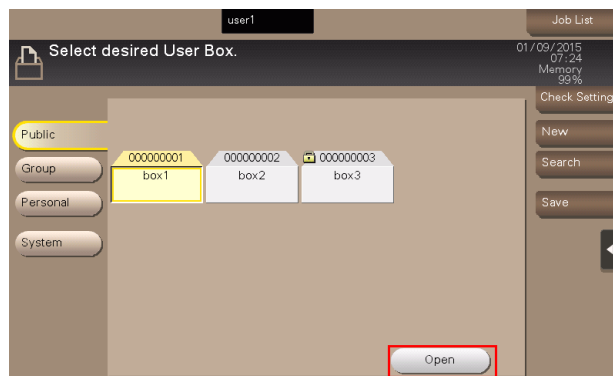

- 3 Select a file to send, then tap [Send].

→ You can also long-tap the target file to display the menu icon, then drag and drop it to  to get the same result.

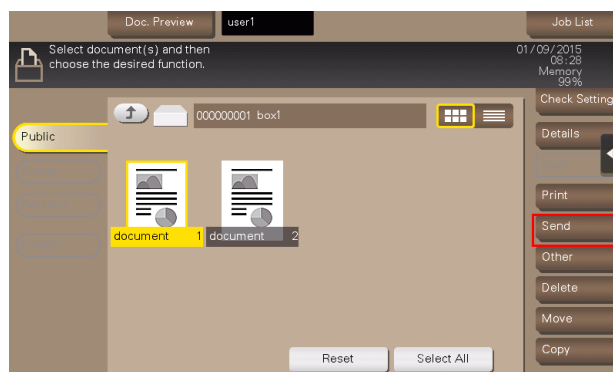

- 4 Specify the destination.
→ For the destination setup, refer to page 2-16.

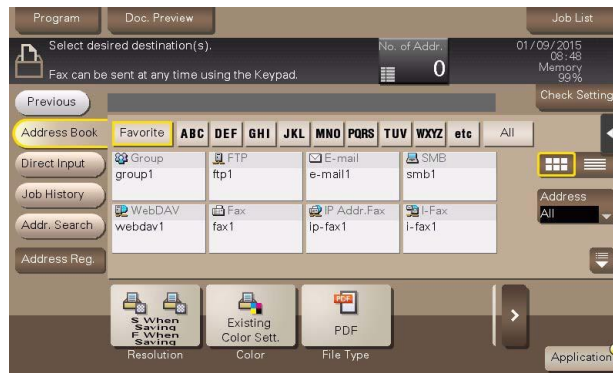

- 5 Set the file send options if necessary.
→ For details, refer to page 13-26.
- 6 Press the **Start** key.
Transmission begins.



Related setting (for the administrator)

- You can specify to hold or clear a file from the box after file printing or sending (Default: [Yes]). Also, you can prompt the user to hold or not hold a file in the box after it has been printed or sent in the delete confirmation screen. For details, refer to "User's Guide[Descriptions of Functions/Utility Keys]/[Utility]".

2.6.2 Set a Destination

Selecting from address book

In [Address Book], select the destination registered on this machine.

You can send data by broadcast transmission if you select multiple destinations. You can also use broadcast transmission by combining different sending modes such as Scan to E-mail and SMB Send.

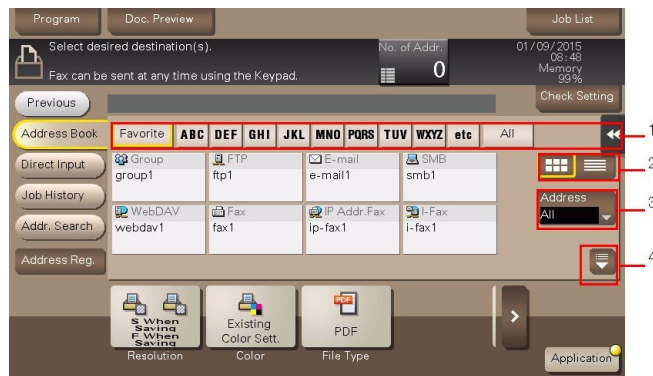

No.	Description
1	Narrow down destinations with the index specified for the registered destination. Using [Address] in combination further narrows down destinations. The following keys can be used to narrow down destinations: <ul style="list-style-type: none"> • [All]: All address book entries registered on this machine are displayed. • [Favorite]: The destinations specified with [Favorite] as search text are displayed. • [etc]: Displays destinations for which the registered name of each begins with a character other than an alphabet character.
2	Switches the display of the registered destinations to the button or list view mode. If the list view mode is selected, you can sort destinations by registration number, destination type, or registered name.
3	Narrow down destinations by the type of the registered destination. Using also search text further narrows down destinations.
4	Expands the area when scrolling is required in the area where the registered destinations are displayed.

Searching for destinations

If a large number of destinations are registered, you can search for a destination by registration name or destination (E-mail address or PC name).

- 1 Tap [Addr. Search] - [Search] - [Name Search] or [Address Search].
 - When searching for a destination by registration name, tap [Name Search].
 - When searching for a destination by E-mail address or computer name, tap [Address Search].
- 2 Enter the text you want to search for, then tap [Search].
- 3 Select a destination from the search result.

Direct input

In [Direct Input], tap the destination type key and enter the destination name.

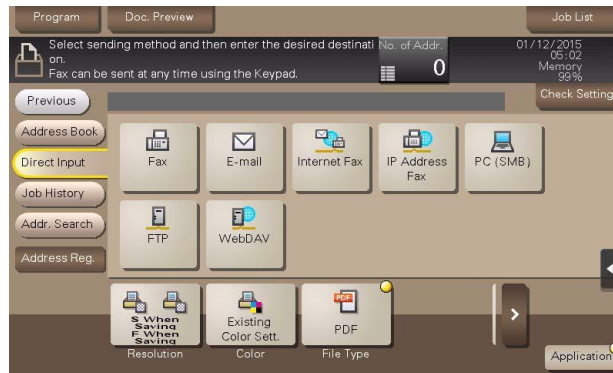

Purpose	Reference
To send fax	"User's Guide[Descriptions of Functions/Utility Keys]/[Scan/Fax]"
To send e-mail with an attached file	"User's Guide[Descriptions of Functions/Utility Keys]/[Scan/Fax]"
To send Internet fax	"User's Guide[Descriptions of Functions/Utility Keys]/[Scan/Fax]"
To send IP Address fax	"User's Guide[Descriptions of Functions/Utility Keys]/[Scan/Fax]"
To send data to a shared folder of a computer or server	"User's Guide[Descriptions of Functions/Utility Keys]/[Scan/Fax]"
To send data to the FTP server	"User's Guide[Descriptions of Functions/Utility Keys]/[Scan/Fax]"
To send data to the WebDAV server	"User's Guide[Descriptions of Functions/Utility Keys]/[Scan/Fax]"

ⓘ Reference

You can register the destination that you have entered directly into the address book. For details on how to register it, refer to "User's Guide[Scan Operations]/[Managing Destinations]".

Selecting from the history

Tap [Job History], and you can select a destination from the scan or fax history.

The latest jobs (up to five) are displayed for history purposes. You can also select multiple destinations from the history.

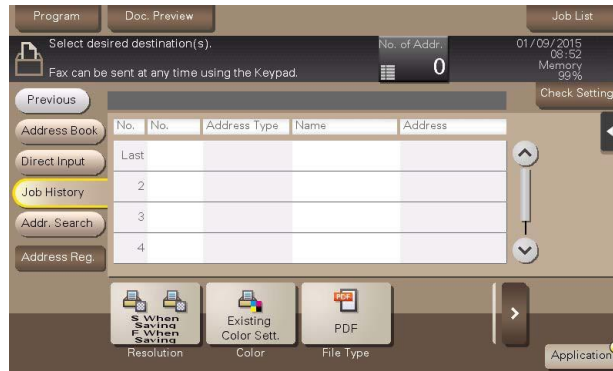

Tips

- If you have edited a destination, you have edited a User Box, or you have turned the power supply Off and On again, the history data is deleted or lost.

Search for mail address or fax number from the LDAP server

If you are using the LDAP server or the Active Directory of Windows Server, you can search and select a mail address from the server.

- © To use the LDAP server or Active Directory to specify the destination, you must register the server to this machine. The registration procedure is explained using **Web Connection**. For details, refer to "User's Guide[Web Management Tool]/[Configuring the Scan Environment]".

- 1 Tap [Addr. Search] - [Search] - [Address Search (LDAP)] or [Adv. Search (LDAP)].
 - When searching using a single keyword, tap [Address Search (LDAP)].
 - When searching by combining keywords in different categories, tap [Adv. Search (LDAP)].
- 2 Enter the keyword, then tap [Search].
- 3 Select a destination from the search result.

2.6.3 Send Multiple Files at the Same Time (Combine TX)

When sending multiple files at the same time, you can combine those files and handle them as a single job. This is called the Combine TX.

Using this function, you can reduce the print time and improve the efficiency as you can skip to repeat sending files one by one. You can collectively print up to 10 files.

- 1 Tap [User Box].



- 2 Select the desired User Box, then tap [Open].
 - This example uses the Public User Box for explanatory purposes. To use a Personal User Box or a Group User Box, tap [Personal] or [Group] and select the desired box.
 - If the box is password protected, tap [Open] and enter the password.
 - You can also open the desired User Box by tapping it twice.

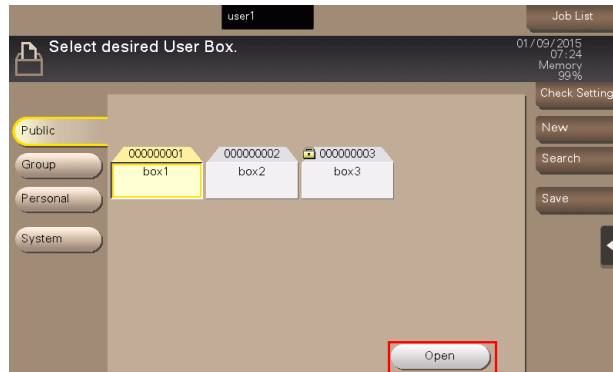

- 3 Select files for Combine TX, then tap [Other] - [Combine TX].

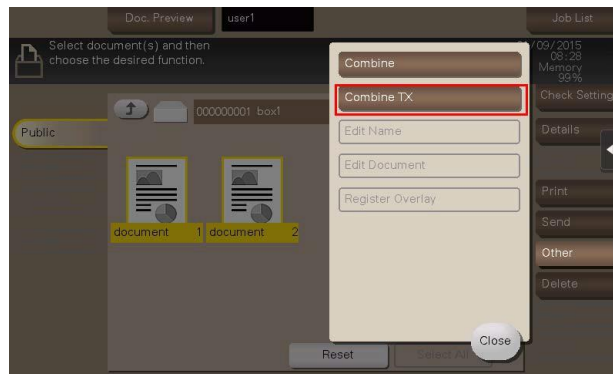

- 4 Change the file sequence (Combine TX sequence) if necessary, then tap [OK].



- 5 Specify the destination.
→ For the destination setup, refer to page 2-21.

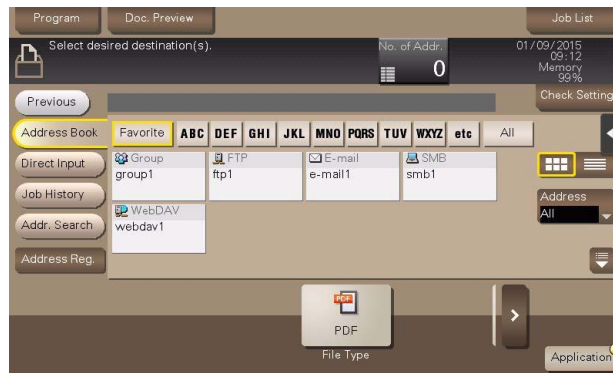

- 6 Set the file send options if necessary.
→ For details, refer to page 13-26.
- 7 Press the **Start** key.
Transmission begins.



Related setting (for the administrator)

- You can specify to hold or clear a file from the box after file printing or sending (Default: [Yes]). Also, you can prompt the user to hold or not hold a file in the box after it has been printed or sent in the delete confirmation screen. For details, refer to "User's Guide[Descriptions of Functions/Utility Keys]/[Utility]".

2.6.4 Specify the Destination (for Combine TX)

Selecting from address book

In [Address Book], select the destination registered on this machine.

You can send data by broadcast transmission if you select multiple destinations. You can also use broadcast transmission by combining different sending modes such as Scan to E-mail and SMB Send.

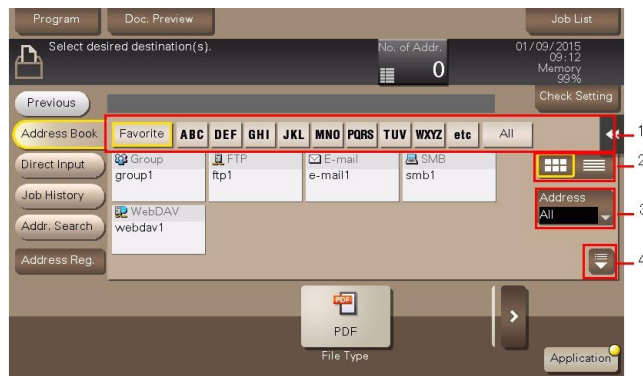

No.	Description
1	Narrow down destinations with the index specified for the registered destination. Using [Address] in combination further narrows down destinations. The following keys can be used to narrow down destinations: <ul style="list-style-type: none"> • [All]: All address book entries registered on this machine are displayed. • [Favorite]: The destinations specified with [Favorite] as search text are displayed. • [etc]: Displays destinations for which the registered name of each begins with a character other than an alphabet character.
2	Switches the display of the registered destinations to the button or list view mode. If the list view mode is selected, you can sort destinations by registration number, destination type, or registered name.
3	Narrow down destinations by the type of the registered destination. Using also search text further narrows down destinations.
4	Expands the area when scrolling is required in the area where the registered destinations are displayed.

Searching for destinations

If a large number of destinations are registered, you can search for a destination by registration name or destination (E-mail address or PC name).

- 1 Tap [Addr. Search] - [Search] - [Name Search] or [Address Search].
 - When searching for a destination by registration name, tap [Name Search].
 - When searching for a destination by E-mail address or computer name, tap [Address Search].
- 2 Enter the text you want to search for, then tap [Search].
- 3 Select a destination from the search result.

Direct input

In [Direct Input], tap the destination type key and enter the destination name.

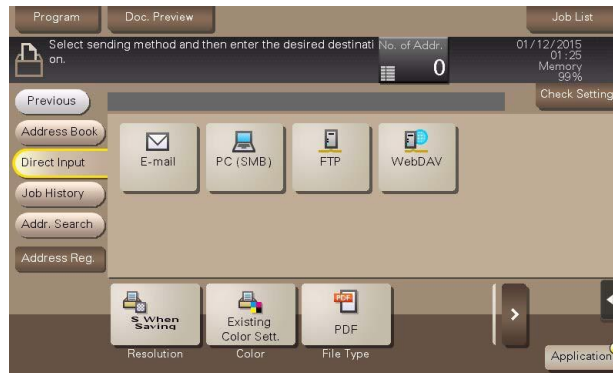

Purpose	Reference
To send e-mail with an attached file	"User's Guide[Descriptions of Functions/Utility Keys]/[Scan/Fax]"
To send data to a shared folder of a computer or server	"User's Guide[Descriptions of Functions/Utility Keys]/[Scan/Fax]"
To send data to the FTP server	"User's Guide[Descriptions of Functions/Utility Keys]/[Scan/Fax]"
To send data to the WebDAV server	"User's Guide[Descriptions of Functions/Utility Keys]/[Scan/Fax]"

⦿ Reference

You can register the destination that you have entered directly into the address book. For details on how to register it, refer to "User's Guide[Scan Operations]/[Managing Destinations]".

Select file from the history

Tap [Job History], and you can select a destination from the scan or saved job history.

The latest jobs (up to five) are displayed for history purposes. You can also select multiple destinations from the history.



 **Tips**

- If you have edited a destination, you have edited a User Box, or you have turned the power supply Off and On again, the history data is deleted or lost.

Searching for an E-mail address through the LDAP server

If you are using the LDAP server or the Active Directory of Windows Server, you can search and select a mail address from the server.

- © To use the LDAP server or Active Directory to specify the destination, you must register the server to this machine. The registration procedure is explained using **Web Connection**. For details, refer to "User's Guide[Web Management Tool]/[Configuring the Scan Environment]".

- 1 Tap [Addr. Search] - [Search] - [Address Search (LDAP)] or [Adv. Search (LDAP)].
 - When searching using a single keyword, tap [Address Search (LDAP)].
 - When searching by combining keywords in different categories, tap [Adv. Search (LDAP)].
- 2 Enter the keyword, then tap [Search].
- 3 Select a destination from the search result.

2.7 Organize Files in a User Box

Operation flow

1 Tap [User Box].

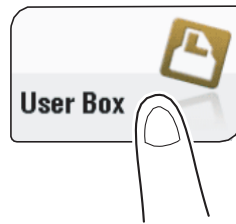

2 Select the desired User Box, then tap [Open].

→ This example uses the Public User Box for explanatory purposes. To use a Personal User Box or a Group User Box, tap [Personal] or [Group] and select the desired box.

→ If the box is password protected, tap [Open] and enter the password.

→ You can also open the desired User Box by tapping it twice.

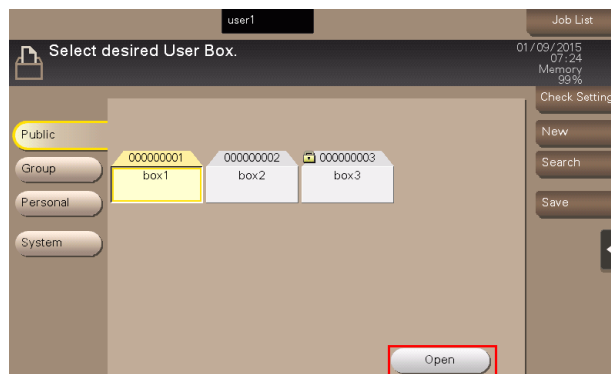

3 Select a file and set the desired operation.

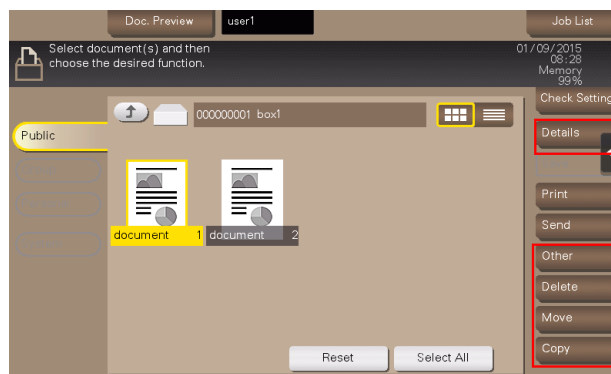

→ Long-tap the file to display the menu icon that is controllable, and the drag and drop operation becomes possible.

Delete a file

Select a file, then tap [Delete]. The file is deleted. You can also long-tap the target file to display the menu icon, then drag and drop it to  to get the same result.

You can select multiple files and delete them simultaneously. Check the file details, then tap [Yes].

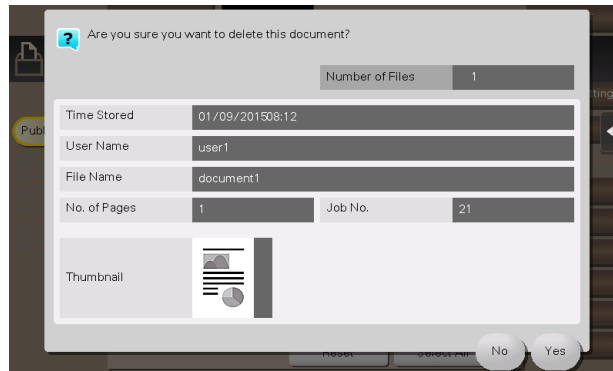

Rename a file

Select a file, then tap [Other] - [Edit Name]. Now you can rename the file. Enter a new name from the **Touch Panel**.

Tips

- Before renaming a file, check the destination server conditions and others.
- You can also rename a file while it is being transmitted.

Move file to another User Box

Select a file, then tap [Move]. Now you can move the file to another User Box. The destination can be a Public User Box, a Personal User Box, or a Group User Box. Select a destination User Box, then tap [Start] or press the **Start** key.

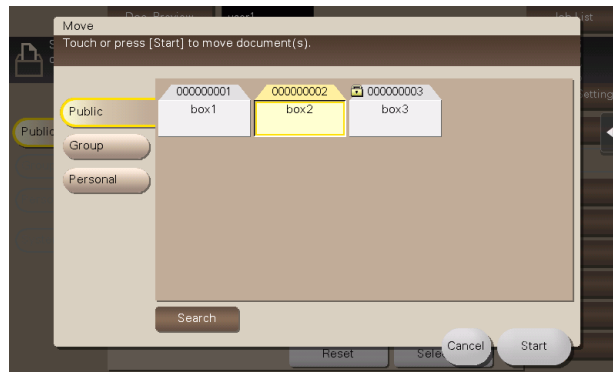

Tips

- You do not need to enter the password even if it is specified for the destination User Box.

Copy file to another User Box

Select a file, then tap [Copy]. Now you can copy the file to another User Box. Select the destination Public, Personal or Group User Box. Select a destination User Box, then tap [Start] or press the **Start** key.



Tips

- You do not need to enter the password even if it is specified for the destination User Box.



Edit a page

Select a file, then tap [Other] - [Edit Document]. Now you can select page of the file to delete or rotate.

You can also long-tap the target file to display the menu icon, then drag and drop it to  to get the same result.

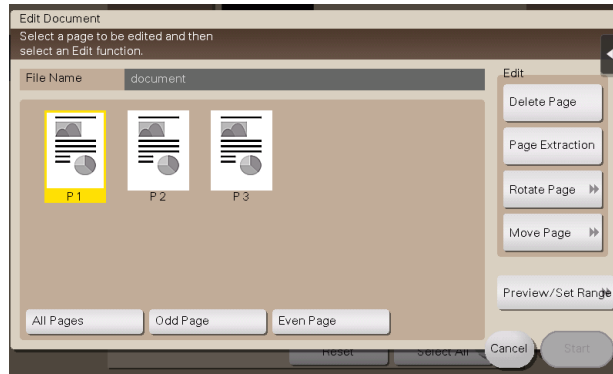
- 1 Select a page, and set the edit options.



Function	Description
[Odd Page]	Selects odd-numbered pages only.
[Even Page]	Selects even-numbered pages only.
[All Pages]	Selects all pages.
[Delete Page]	Deletes a selected page or pages. For example, you can delete blank pages to reduce the amount of data. You can also long-tap the target page to display the menu icon, then drag and drop it to  to get the same result.
[Page Extraction]	Extracts a selected page. When there are too many pages to be deleted, selecting the page only you need to reserve eliminates the need for deleting after selecting many pages. You can also long-tap the target page to display the menu icon, then drag and drop it to  to get the same result.
[Rotate Page]	Rotates a selected page 90 degrees or 180 degrees. When a 2-sided original is scanned, the top and bottom may be reversed page by page or the orientation may be different from the original. In this case, you can rotate and correct the orientation of each page. You can also long-tap the selected page to display the menu icon, then drag and drop it to  to get the same result.
[Move Page]	Reorders pages by moving some of them. Only one page can be moved at a time. Repeat this operation to move two or more pages. You can also drag and drop the target page to the desired place to sort pages. <ul style="list-style-type: none"> • [Preview/Specify by Input]: If a large number of pages are stored, use this option to set the destination to move pages by entering numeric values. Enter a destination page number, and specify to insert the page immediately before or after the destination.
[Preview/Set Range]	Sets a range of pages and displays them as preview image. You can also change the display size.

- 2 Tap [Start].
- 3 To save your changes, tap [Yes].
Your settings are saved.

Save file in a USB memory

Insert a USB memory device into the USB port of this machine, select a file, then tap [Other] - [Save to External Memory]. Now you can save the file on the USB memory.

- © A file storage on a USB memory must first be enabled with the administrator privileges. For details, refer to "User's Guide[Descriptions of Functions/Utility Keys]/[Utility]".
- © Files of some USB memory devices may not be recognized correctly. For support of USB memory devices, refer to page 12-3.

- 1 Select a file to save on the USB memory device, then tap [Other] - [Save to External Memory].
→ You can also long-tap the target file to display the menu icon, then drag and drop it to  to get the same result.

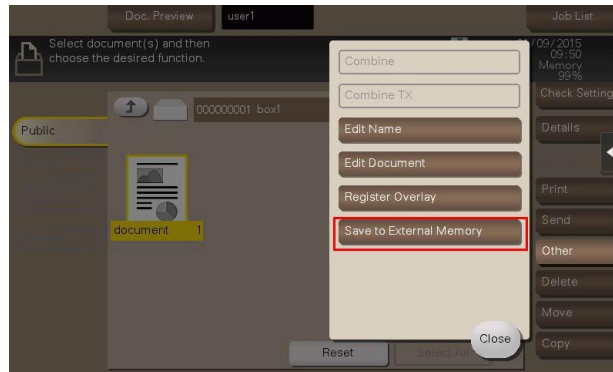

- 2 Set file save options if necessary.

Options	Reference
Resolution	page 13-3
Color	page 13-3
File Type	page 13-4

- 3 Press the **Start** key.
The file is saved on the USB memory device.



- 4 When the operation is complete, remove the USB memory device from the port of this machine.

Store file as an overlay image

Select a file, then tap [Other] - [Register Overlay]. Now you can store a file as an overlay image.

Once registered, you can compose an overlay image on the original during copy or printing from the PC. Also, you can compose an overlay image onto a User Box file during file printing.

You can register up to 100 overlay images.

- © This function is available when this machine is equipped with an optional **Extension Memory**.

- 1 To register an overlay image, select an unregistered key and tap [New].
 - To register an overlay image by overwriting an existing one, select the registered key and tap [Overwrite].

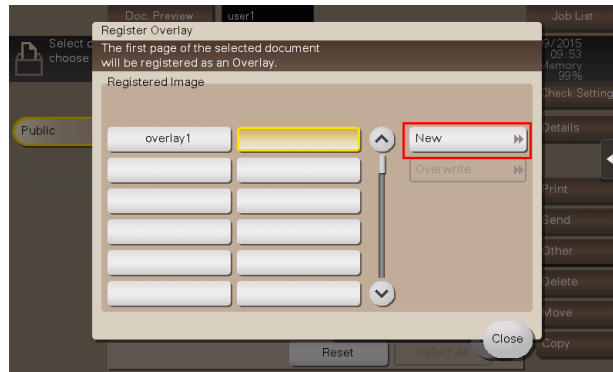

- 2 Enter a registration name, then tap [OK].
- 3 Set a density of image if necessary, then tap [Start].

Tips

- If a file consists of multiple pages, the first page is registered as an overlay image.
- Once registered, you can compose an overlay image on the original and copy it by selecting [Application] in Copy mode and [Registered Overlay]. Also, when you print a file from a User Box, you can compose an overlay image to the file and print it by selecting [Application] - [Registered Overlay].

Re-create a file in an SMB sharing

This function is available when files in the Public User Box are shared on the network using the Share SMB File function.

Select a file, then tap [Other] - [Save Document to MFP Shared Folder]. Now you can register files saved in the Public User Box in an SMB sharing folder.

Use this function to convert a document saved in a User Box using the scan function or User Box function into a general format, or to re-register a file deleted from a shared folder via a computer to the shared folder.

Check the file information

Select a file, then tap [Details] to check the detailed file information.

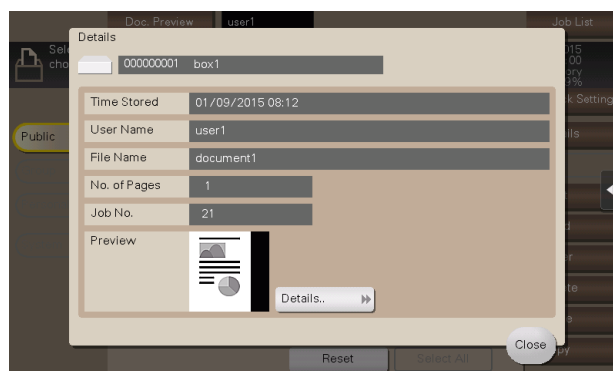

You can tap [Details..] or a thumbnail image to preview the file image.

If you tap the tab key on the right of the screen, you can display or hide the Setting Key. The Setting Key allows you to enlarge or reduce a preview image.

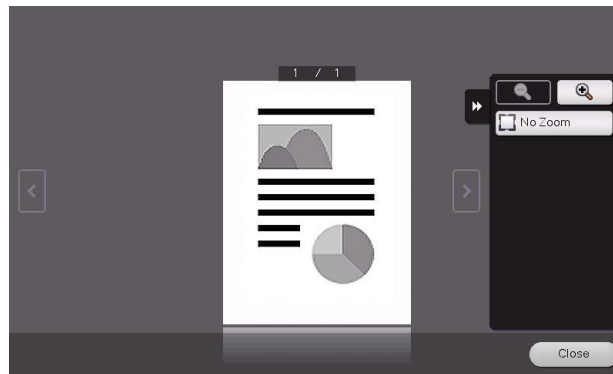

2.8 Operate a User Box from the PC

2.8.1 Operate a User Box via Web Connection

Open User Box

Log in to the **Web Connection** user mode, and open a User Box.

- 1 Access to the **Web Connection**, using the Web browser.
 - For details on how to access Web Connection, refer to "User's Guide[Web Management Tool]/[Basic Usage]".
- 2 Log in to the user mode.
 - For details on how to login to the user mode, refer to "User's Guide[Web Management Tool]/[Basic Usage]".
- 3 Click [Box] - [Open User Box].

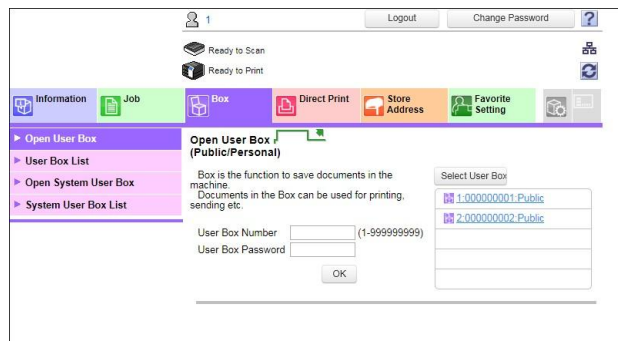

- 4 Click and select a User Box to open from the list.
 - If the User Box list does not include the desired User Box, first click [Select User Box], select the check box for the User Box to be displayed in the list, then click [OK] in advance.
 - You can also open a desired User Box by entering its number directly in the [User Box Number] column.
 - If the box is password protected, you need to enter the password.

Printing a file in a User Box

If a file can be printed, a check box is shown in the [Select] column. Also, symbol  is shown in the [Selectable Operation] column.

- 1 Select the check box of file you wish to print, and click [Print].
 - You can also click  in the [Selectable Operation] column of the file to be printed to perform the same operation.

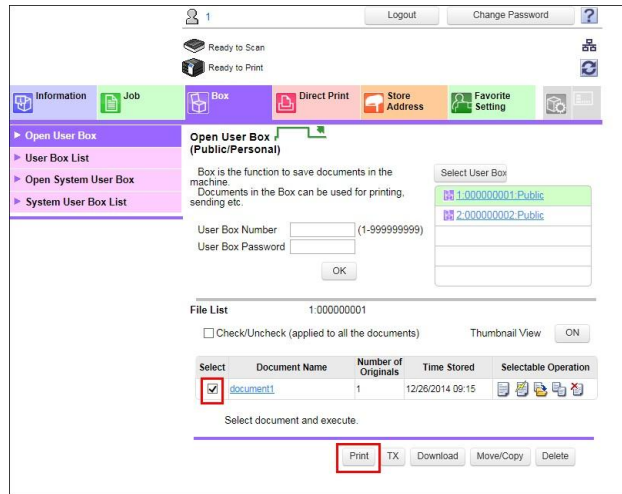



- 2 Set the print options if necessary.

Settings	Description
[Change order]	This option is displayed when multiple files are selected. You can change the print sequence if necessary. Select files and change their print sequence by clicking [Top]/[Up]/[Down]/[Bottom]/[Undo]. To display files as thumbnails, click [Thumbnail View].
[Combine]	This option is displayed when multiple files are selected. You can combine multiple files into a single file and print them at the same time. If you select multiple files and set [OFF], you cannot use the [Basic Setting] and [Application Setting] options.
[Basic Setting]	You can set a number of copies, 2-sided Print, and Finishing if necessary.
[Application Setting]	Configure more detailed setting such as Page Margin or Stamp. When using this function, click [Display].
[Save Print Settings]	Specify to save the current print settings or not. This option is not displayed when multiple files are selected.

- 3 Click [OK].
Printing starts.
- 4 Click [OK].
The file list screen appears again.

Send files in a User Box

If a file can be sent, a check box is shown in the [Select] column. Also, symbol  is shown in the [Selectable Operation] column.

- 1 Select the check box of file you wish to send, and click [TX].
→ You can also click  in the [Selectable Operation] column of the file to be sent to perform the same operation.

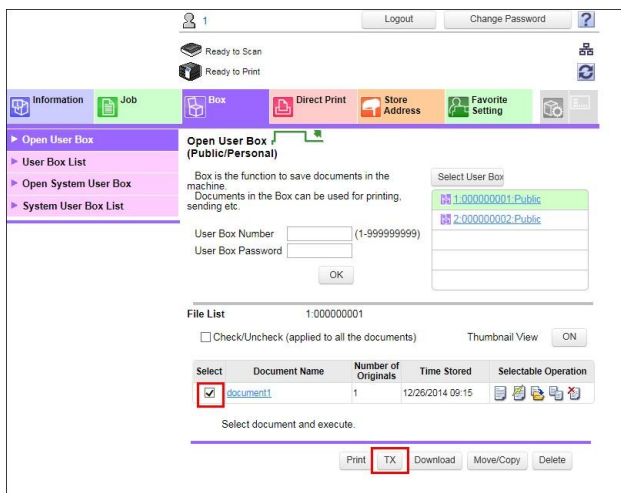

- 2 Configure send settings.

Settings	Description
[Specify destination]	Click [Search from List], and select the destination from the Address Book. When checking the destination list, click [Check Destination].
[Change order]	This option is displayed when multiple files are selected. You can change the file transfer sequence if necessary. Select files and change their print sequence by clicking [Top]/[Up]/[Down]/[Bottom]/[Undo]. To display files as thumbnails, click [Thumbnail View].
[Bind TX]	This option is displayed when multiple files are selected. You can combine multiple files into a single file and send them at the same time. If you select multiple files and set [OFF], you cannot use the [File Type] and [Application Setting] options.
[File Type]	Specify the file type and encryption contents for a file to be sent.
[Communication Setting]	Configure E-mail settings or specify the URL notification destination. When using this function, click [Display].
[Application Setting]	Configure more detailed setting such as Stamp or Send & Print. When using this function, click [Display].

- 3 Click [OK].
Transmission begins.
- 4 Click [OK].
The file list screen appears again.

Download files in a User Box to the PC

If a file can be downloaded, a check box is shown in the [Select] column. Also, symbol  is shown in the [Selectable Operation] column. The file size of up to 400 MB can be downloaded at one time.

- © If the file size exceeds 400 MB, specify the page range setting before downloading to limit the file size to download at one time to less than 400 MB.

- 1 Select the check box of file you wish to download, and click [Download].
→ You can also click  in the [Selectable Operation] column of the file to be downloaded to perform the same operation.

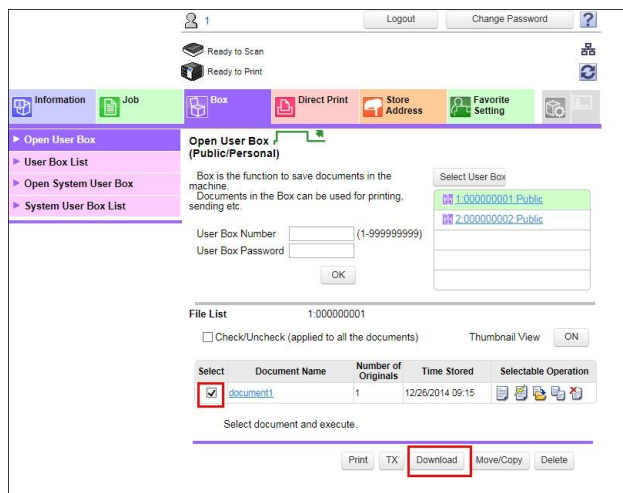



- 2 Set the download options.

Settings	Description
[Change the settings.]	This option is displayed when downloading files from a Public User Box that has the Share SMB File function specified. If the Share SMB File function is enabled and a general format file exists in an SMB sharing folder, clear the [Change the settings.] check box. You will then be able to directly download files from the SMB sharing folder. This allows higher speed downloading. If no general format file exists in an SMB sharing folder, select the [Change the settings.] check box. You will then be able to download files by converting them into a general format.
[Change order]	This option is displayed when multiple files are selected. You can change the file storage sequence if necessary. Select files and change their print sequence by clicking [Top]/[Up]/[Down]/[Bottom]/[Undo]. To display files as thumbnails, click [Thumbnail View].
[File Format]	Select a type of file to save.
[Page Range]	You can download all pages of file or the specified range of pages to the PC.

- 3 Click [OK].
- 4 When [Preparation for download has been completed.] has appeared, click [Download].
The File Download page appears.
- 5 Click [Save].
- 6 Specify the storage location and file name, and click [Save].
- 7 Click [Back].
The file list screen appears again.

Move or copy files in a User Box to another User Box

If a file can be moved or copied to another User Box, a check box is shown in the [Select] column. Also, symbol  is shown in the [Selectable Operation] column.

- 1 Select the check box of file you wish to move or copy, and click [Move/Copy].
 - You can also click  in the [Selectable Operation] column of the file to be moved or copied to perform the same operation.
 - You cannot select multiple files.

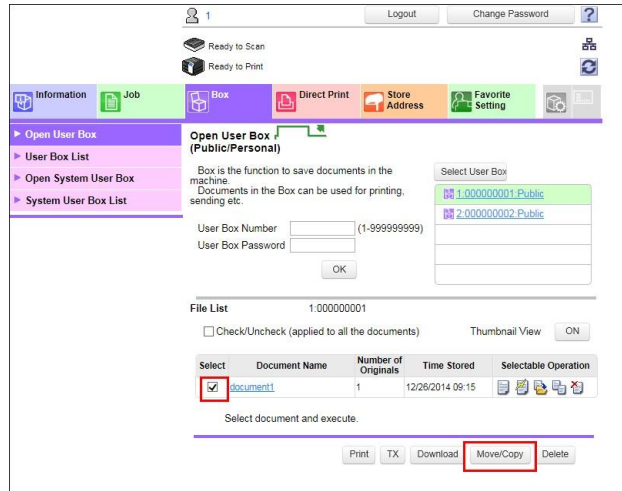



- 2 Set the move or copy options.

Settings	Description
[User Box Number]	Select the destination User Box from the box list.
[Copy]	Select this check box to copy a file to the selected User Box.

- 3 Click [OK].
The file is moved or copied to the destination User Box.
- 4 Click [OK].
The file list screen appears again.

Delete files from a User Box

If a file can be deleted, a check box is shown in the [Select] column. Also, symbol  is shown in the [Selectable Operation] column.

- 1 Select the check box of file you wish to delete, and click [Delete].
 - You can select or deselect all files by checking the [Check/Uncheck (applied to all the documents)] box.
 - You can also click  in the [Selectable Operation] column of the file to be deleted to perform the same operation.

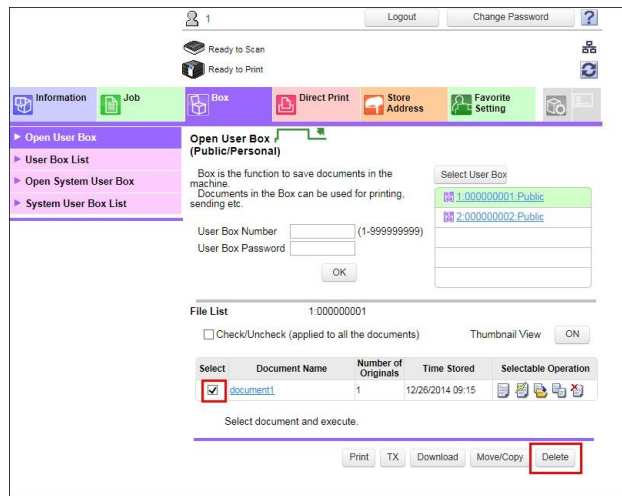

- 2 Check the name of file to delete, and click [OK].
 - When you select multiple files and display them as thumbnails, click [Thumbnail View].
- 3 Click [OK].
 - The file is deleted, and the file list screen appears again.

2.8.2 Operate a User Box using the Box Operator

Box Operator is application software to access files saved in a User Box from a Windows computer.

You can view the contents of a file as thumbnail images, and perform operations such as printing, deletion, and copying to a computer.

To download **Box Operator**, select [PageScope Utilities] in the **Driver & Utilities CD-ROM Vol.1** or **Driver & Utilities CD-ROM Vol.2** menu, then display the page to download utility software. For details on how to install or use this application, refer to the relevant manual of **Box Operator**.

2.9 Sharing files in the Public User Box on the Network (Share SMB File)

Share SMB File

Share SMB File is a function that shares files in the Public User Box of the machine on the network using the machine as an SMB server.

This function allows you to connect to the device through the computer and easily export files in the Public User Box in the same way as when referencing the shared folder on the network.

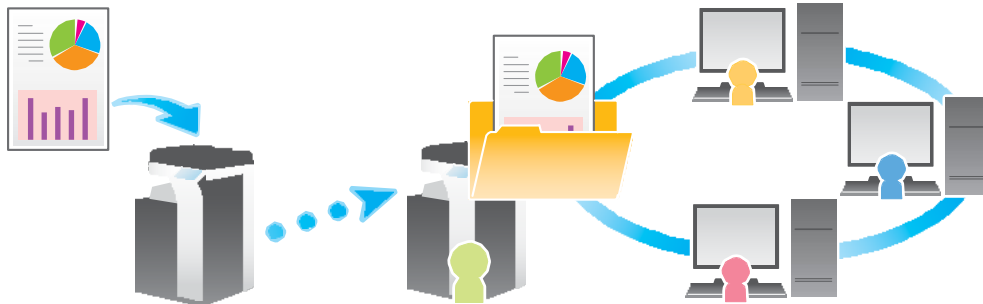

Operations required to use this function (For administrators)

Enable the Share SMB File function of the machine, then register a Public User Box used to share files.

How to configure the setting is explained using **Web Connection**. For details, refer to "User's Guide[Web Management Tool]/[Configuring the User Box Environment]".

Related setting (for the administrator)

- You can set a time to delete files automatically from the SMB folder using the Public User Box (Default: [1 day]). For details, refer to "User's Guide[Descriptions of Functions/Utility Keys]/[Utility]".
- If the total file size in the SMB folder exceeds 90% of the available hard disk capacity, a notification is sent to the E-mail address of the User Box administrator. If the User Box administrator's E-mail address has not been set, a notification is sent to the E-mail address of the machine administrator. For details on the User Box administrator settings, refer to "User's Guide[Descriptions of Functions/Utility Keys]/[Utility]".

Saving files in the Public User Box

Only the files saved in the Public User Box as described below can be shared on the network.

- Files saved to the Public User Box in user box mode
- For details on the operation procedure, refer to page 2-9.
- Files saved to the Public User Box in fax/scan mode
- For details on the operation procedure, refer to "User's Guide[Scan Operations]/[Saving a file in a User Box of this Machine (Save in User Box)]".

Tips

- Files saved to the Public User Box from the copy mode, printer driver, or USB memory cannot be shared on the network.

Referencing files in the Public User Box through the computer

This function allows you to connect to the device through the computer and easily export files in the Public User Box in the same way as when referencing the shared folder on the network.

- The folder name of the Public User Box referenced through the computer is "9-digit User Box number_User Box name".
- If the Public User Box is protected by the password, the following ID and password are required for authentication to reference files in the Public User Box.
- ID: User Box number
- Password: Password specified for the Public User Box
- If a User Box administrator is specified, its ID and password are required for authentication to reference files in the Public User Box, which is protected by the password.

⊙ Reference

Using **Web Connection** allows you to download files in the Public User Box to a computer. For details, refer to page 2-34.



**Receive Fax in Memory and
Print It Later ([Memory RX])**

3 Receive Fax in Memory and Print It Later ([Memory RX])

3.1 [Memory RX]

When a facsimile is received by the Memory RX function, it is stored in the Memory RX User Box. Once you have opened the User Box, you can select a fax stored in the User Box and preview, print, send, rename, or delete it.

Because the received faxes are forcibly stored in this box, you can print out only the required faxes and subsequently reduce total printing costs. Also, this will prevent important faxes from being stolen or lost and therefore enhance security.

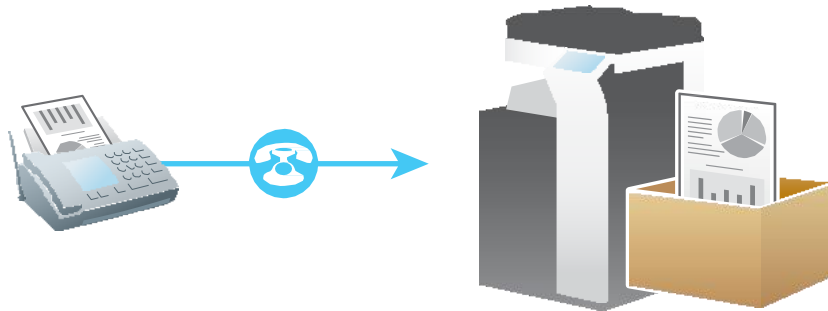

Tips

- The **Hard Disk** is optional in some areas. To use this function, install the optional **Hard Disk** and **FAX Kit** in this machine or enable the Internet Fax function. Internet Fax must be configured by your service representative. For details, contact your service representative.
- The Memory RX User Box can store up to 500 documents.
- The optional **Extension Memory** and **i-Option LK-110 v2** are required to send a fax saved in the Memory RX User Box.

Related setting

- If you often use the Memory RX User Box, it will be useful to place its shortcut key on the top screen. For details, refer to "User's Guide[Descriptions of Functions/Utility Keys]/[Utility]".

3.2 Print Fax in a User Box

- 1 Tap [User Box].

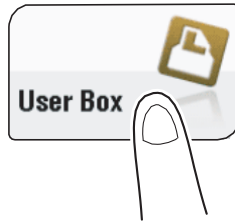

- 2 Tap [System] - [Memory RX].

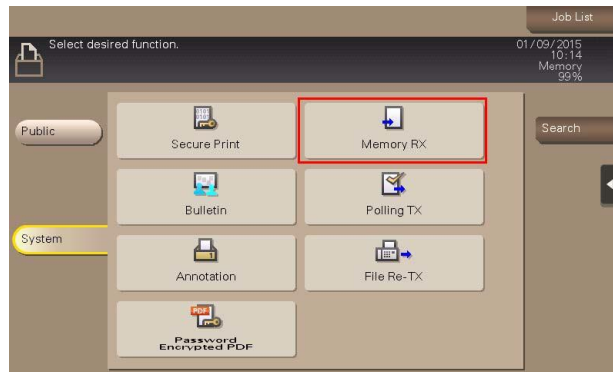

- 3 Enter the password, then tap [OK].

- 4 Select a fax to print, then tap [Print].

→ You can also long-tap the target file to display the menu icon, then drag and drop it to  to get the same result.

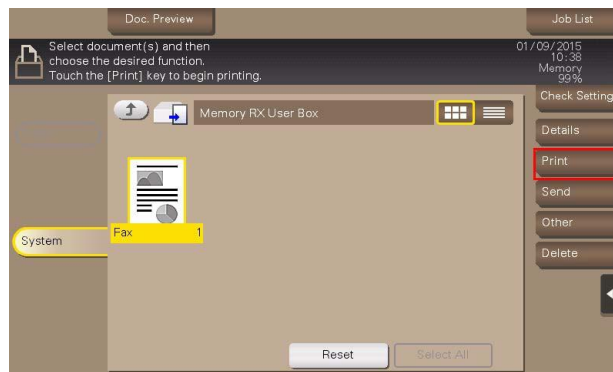

- 5 To execute this print job, tap [Yes].

Tips

- When you print a fax, it is deleted from the Memory RX User Box automatically.

3.3 Send Fax in a User Box

3.3.1 Sending (basic operation flow)

- © The optional **Extension Memory** and **i-Option LK-110 v2** are required to send a fax saved in the Memory RX User Box.

- 1 Tap [User Box].



- 2 Tap [System] - [Memory RX].

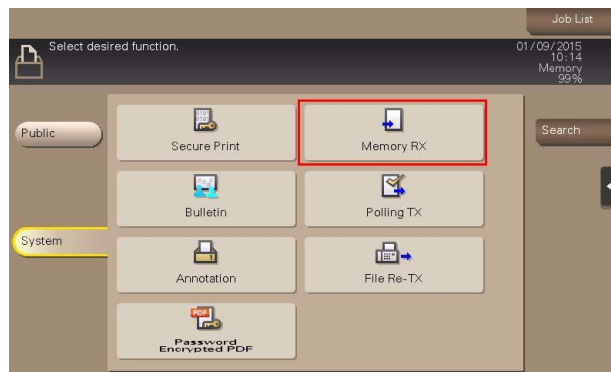

- 3 Enter the password, then tap [OK].

- 4 Select a fax to send, then tap [Send].

→ You can also long-tap the target file to display the menu icon, then drag and drop it to  to get the same result.

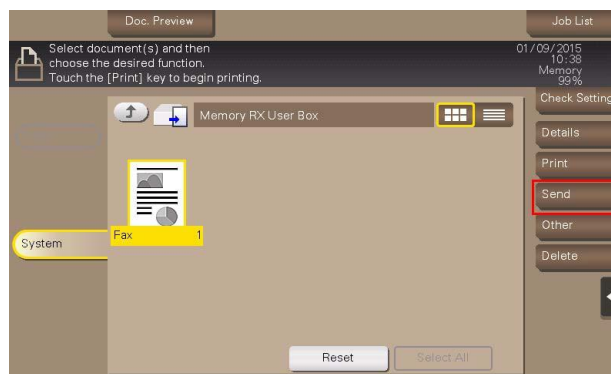

- 5 Specify the destination.
→ For the destination setup, refer to page 3-5.



- 6 Set the file send options if necessary.
→ For detailed optional settings, refer to page 13-27.
- 7 Press the **Start** key.
Transmission begins.



3.3.2 Set a Destination

Selecting from address book

In [Address Book], select the destination registered on this machine.

You can send data by broadcast transmission if you select multiple destinations. You can also use broadcast transmission by combining different sending modes such as Scan to E-mail and SMB Send.

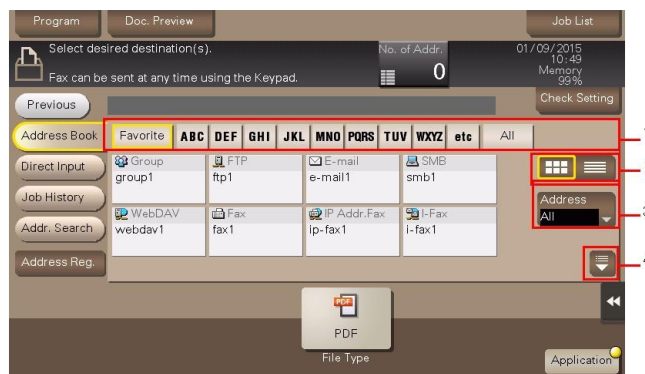

No.	Description
1	Narrow down destinations with the index specified for the registered destination. Using [Address] in combination further narrows down destinations. The following keys can be used to narrow down destinations: <ul style="list-style-type: none"> • [All]: All address book entries registered on this machine are displayed. • [Favorite]: The destinations specified with [Favorite] as search text are displayed. • [etc]: Displays destinations for which the registered name of each begins with a character other than an alphabet character.
2	Switches the display of the registered destinations to the button or list view mode. If the list view mode is selected, you can sort destinations by registration number, destination type, or registered name.
3	Narrow down destinations by the type of the registered destination. Using also search text further narrows down destinations.
4	Expands the area when scrolling is required in the area where the registered destinations are displayed.

Searching for destinations

If a large number of destinations are registered, you can search for a destination by registration name or destination (E-mail address or PC name).

- 1 Tap [Addr. Search] - [Search] - [Name Search] or [Address Search].
 - When searching for a destination by registration name, tap [Name Search].
 - When searching for a destination by E-mail address or computer name, tap [Address Search].
- 2 Enter the text you want to search for, then tap [Search].
- 3 Select a destination from the search result.

Direct input

In [Direct Input], tap the destination type key and enter the destination name.

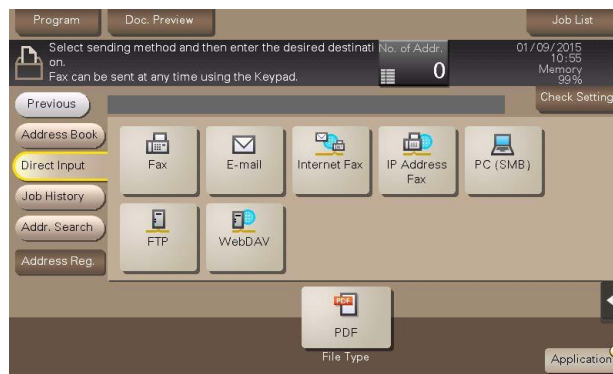

Purpose	Reference
To send fax	"User's Guide[Descriptions of Functions/Utility Keys]/[Scan/Fax]"
To send e-mail with an attached file	"User's Guide[Descriptions of Functions/Utility Keys]/[Scan/Fax]"
To send Internet fax	"User's Guide[Descriptions of Functions/Utility Keys]/[Scan/Fax]"

Purpose	Reference
To send IP Address fax	"User's Guide[Descriptions of Functions/Utility Keys]/[Scan/Fax]"
To send data to a shared folder of a computer or server	"User's Guide[Descriptions of Functions/Utility Keys]/[Scan/Fax]"
To send data to the FTP server	"User's Guide[Descriptions of Functions/Utility Keys]/[Scan/Fax]"
To send data to the WebDAV server	"User's Guide[Descriptions of Functions/Utility Keys]/[Scan/Fax]"

ⓘ Reference

You can register the destination that you have entered directly into the address book. For details on how to register it, refer to "User's Guide[Scan Operations]/[Managing Destinations]".

Select file from the history

Tap [Job History], and you can select a destination from the scan or saved job history.

The latest jobs (up to five) are displayed for history purposes. You can also select multiple destinations from the history.

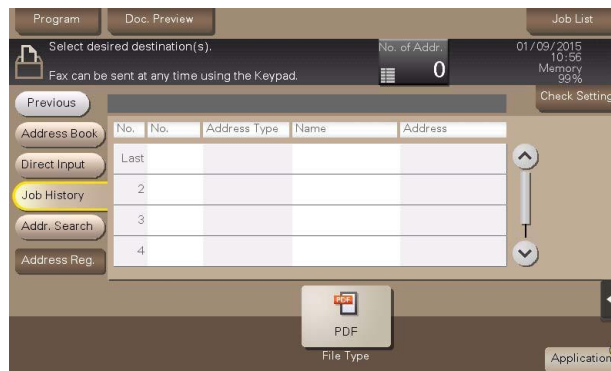

💡 Tips

- If you have edited a destination, you have edited a User Box, or you have turned the power supply Off and On again, the history data is deleted or lost.

Searching for an E-mail address through the LDAP server

If you are using the LDAP server or the Active Directory of Windows Server, you can search and select a mail address from the server.

- Ⓞ To use the LDAP server or Active Directory to specify the destination, you must register the server to this machine. The registration procedure is explained using **Web Connection**. For details, refer to "User's Guide[Web Management Tool]/[Configuring the Scan Environment]".

- 1 Tap [Addr. Search] - [Search] - [Address Search (LDAP)] or [Adv. Search (LDAP)].
 - When searching using a single keyword, tap [Address Search (LDAP)].
 - When searching by combining keywords in different categories, tap [Adv. Search (LDAP)].
- 2 Enter the keyword, then tap [Search].

- 3 Select a destination from the search result.

3.4 Organize Faxes in a User Box

Operation flow

- 1 Tap [User Box].

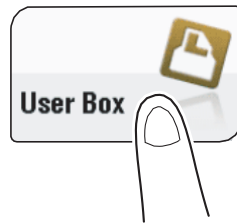

- 2 Tap [System] - [Memory RX].

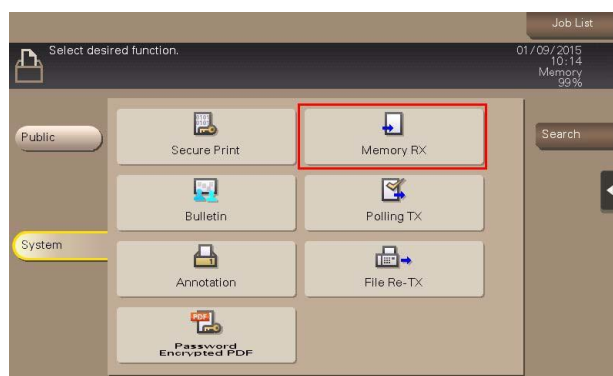

- 3 Enter the password, then tap [OK].

- 4 Select a fax and set an operation for it.

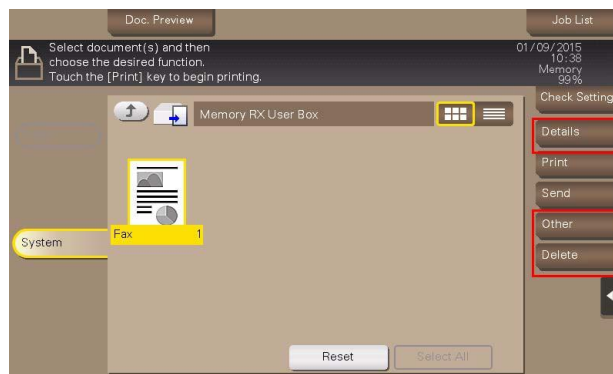

Delete a file

Select a file, then tap [Delete]. The file is deleted. You can also long-tap the target file to display the menu icon, then drag and drop it to  to get the same result.

You can select multiple files and delete them simultaneously. Check the file details, then tap [Yes].

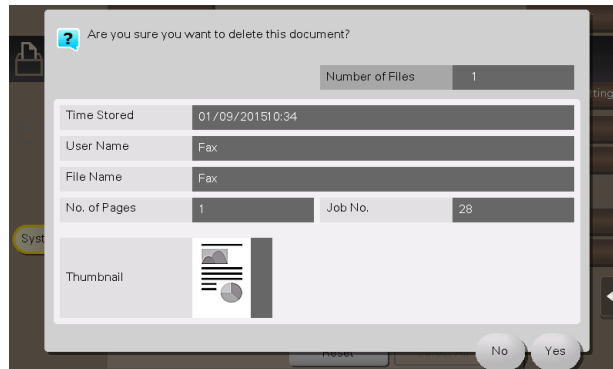

Rename a file

Select a file, then tap [Other] - [Edit Name]. Now you can rename the file. Enter a new name from the **Touch Panel**.



Tips

- Before renaming a file, check the destination server conditions and others.
- You can also rename a file while it is being transmitted.

Check the file information

Select a file, then tap [Details] to check the detailed file information.

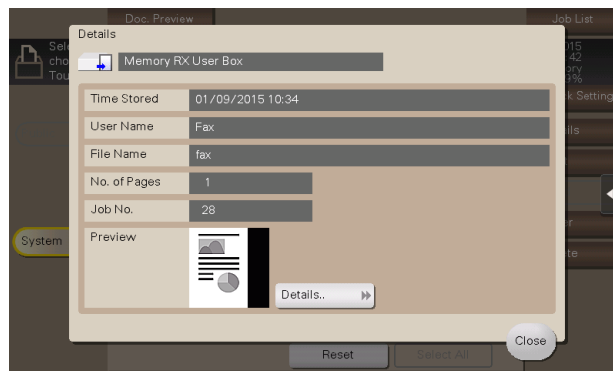

You can tap [Details..] or a thumbnail image to preview the file image.

If you tap the tab key on the right of the screen, you can display or hide the Setting Key. The Setting Key allows you to enlarge or reduce a preview image.

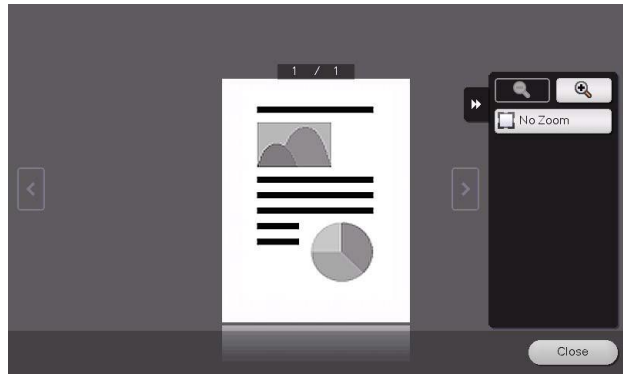

4

**Retransmit Fax If Redialing
Has Failed ([File Re-TX])**

4 Retransmit Fax If Redialing Has Failed ([File Re-TX])

4.1 [File Re-TX]

When the recipient is busy and if communication cannot be established, undeliverable fax documents are stored in the Fax Retransmit User Box. Once you have opened the User Box, you can select a fax document stored in the User Box and preview, print out, send, or delete it.

Fax transmission is attempted for the number of times set by Auto Redialing function. If those attempts have failed, the fax document is stored in the Fax Retransmit User Box.



Tips

- The **Hard Disk** is optional in some areas. To use this function, the optional **Hard Disk** and **Fax Kit** must be installed in this machine.

Related setting

- If you often use the Fax Retransmit User Box, it will be useful to place its shortcut key on the top screen. For details, refer to "User's Guide[Descriptions of Functions/Utility Keys]/[Utility]".

Reference

For details on the Auto Redialing function, refer to "User's Guide[Fax Operations]/[Sending Options]".

4.2 Send Fax in a User Box

4.2.1 Sending (Basic Operation Flow)

- 1 Tap [User Box].



- 2 Tap [System] - [File Re-TX].

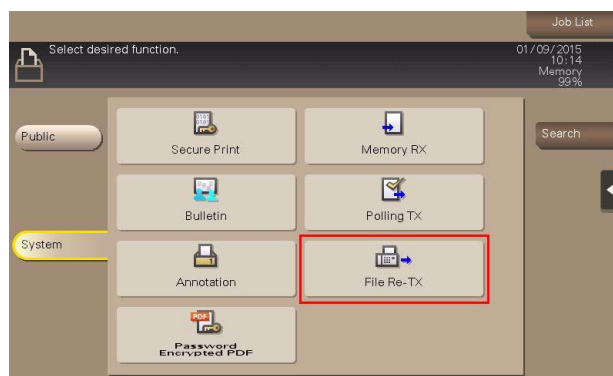

- 3 Select a fax to retransmit, then tap [Fax TX].

→ You can also long-tap the target file to display the menu icon, then drag and drop it to  to get the same result.

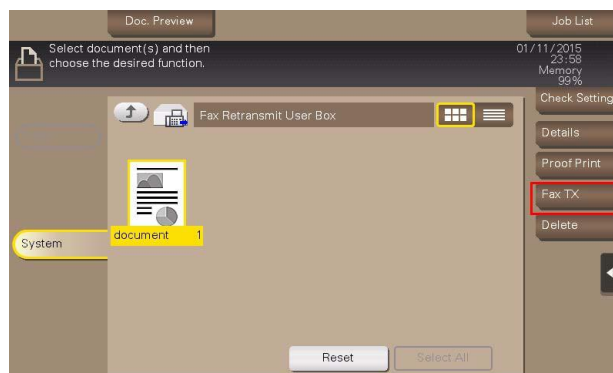

- 4 Specify the destination.
→ For the destination setup, refer to page 4-4.

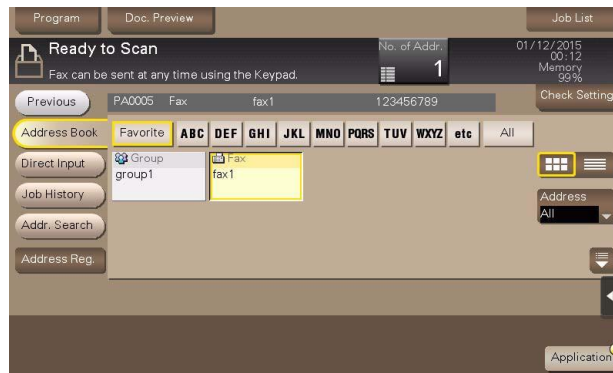

- 5 Set the file send options if necessary.

Options	Reference
[Fax Header Settings]	page 13-32
[Line Setting]	page 13-33

- 6 Press the **Start** key.
Transmission begins.



Tips

- When you retransmit a fax, it is deleted from the Fax Retransmit User Box regardless of whether the transmission was successful or failed.

4.2.2 Set a Destination

Selecting from address book

In [Address Book], select the destination registered on this machine.

You can send data by broadcast transmission if you select multiple destinations.

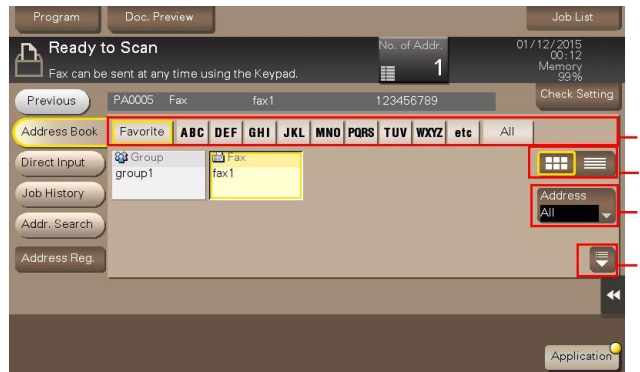

No.	Description
1	Narrow down destinations with the index specified for the registered destination. Using [Address] in combination further narrows down destinations. The following keys can be used to narrow down destinations: <ul style="list-style-type: none"> • [All]: All address book entries registered on this machine are displayed. • [Favorite]: The destinations specified with [Favorite] as search text are displayed. • [etc]: Displays destinations for which the registered name of each begins with a character other than an alphabet character.
2	Switches the display of the registered destinations to the button or list view mode. If the list view mode is selected, you can sort destinations by registration number, destination type, or registered name.
3	Narrow down destinations by the type of the registered destination. Using also search text further narrows down destinations.
4	Expands the area when scrolling is required in the area where the registered destinations are displayed.

Searching for destinations

If a large number of destinations are registered, you can search for a destination by registration name or destination (E-mail address or PC name).

- 1 Tap [Addr. Search] - [Search] - [Name Search] or [Address Search].
 - When searching for a destination by registration name, tap [Name Search].
 - When searching for a destination by E-mail address or computer name, tap [Address Search].
- 2 Enter the text you want to search for, then tap [Search].
- 3 Select a destination from the search result.

Direct input

Select [Direct Input], tap [Fax], then enter a fax number.

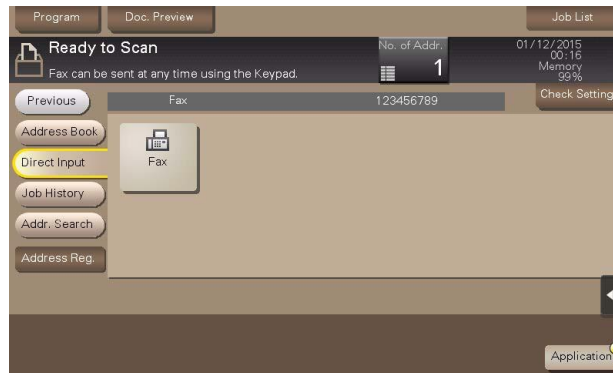

Reference

You can directly enter a destination and store it in the Address Book. For details on how to register it, refer to "User's Guide[Scan Operations]/[Managing Destinations]".

Selecting from the history

Tap [Job History], and you can select a destination from the scan or fax history.

The latest jobs (up to five) are displayed for history purposes. You can also select multiple destinations from the history.

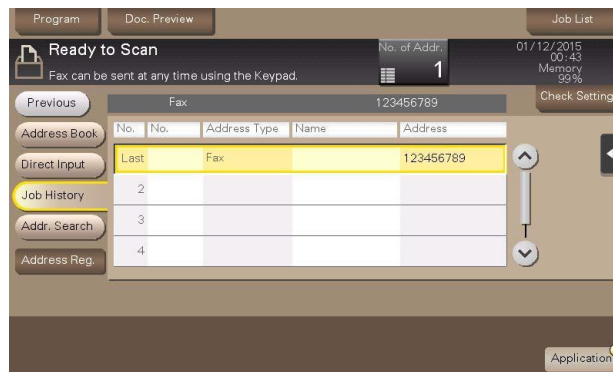

Tips

- If you have edited a destination, you have edited a User Box, or you have turned the power supply Off and On again, the history data is deleted or lost.

Searching for a fax number from the LDAP server

When the LDAP server or Windows Server Active Directory is used, you can search for and select a fax number from the server.

- © To use the LDAP server or Active Directory to specify the destination, you must register the server to this machine. The registration procedure is explained using **Web Connection**. For details, refer to "User's Guide[Web Management Tool]/[Configuring the Scan Environment]".

- 1 Tap [Addr. Search] - [Search] - [Address Search (LDAP)] or [Adv. Search (LDAP)].
 - When searching using a single keyword, tap [Address Search (LDAP)].
 - When searching by combining keywords in different categories, tap [Adv. Search (LDAP)].
- 2 Enter the keyword, then tap [Search].
- 3 Select a destination from the search result.

4.3 Print Fax in a User Box

You can print only the first page of fax being stored in the Fax Retransmit User Box. The fax is not deleted from the box even if it is printed out.

- 1 Tap [User Box].



- 2 Tap [System] - [File Re-TX].

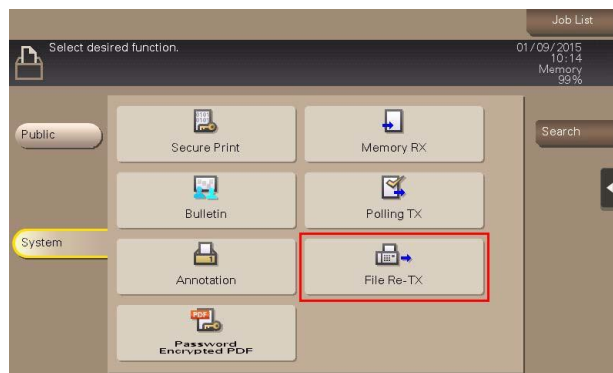

- 3 Select a fax, then tap [Proof Print].

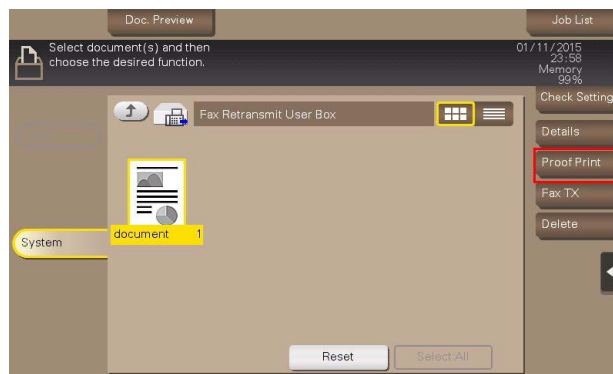

→ You can also long-tap the target file to display the menu icon, then drag and drop it to  to get the same result.

4 Tap [Start].

→ Tap [Details..] or a thumbnail to preview the fax image. For preview image details, refer to "User's Guide[Descriptions of Functions/Utility Keys]/[User Box]".

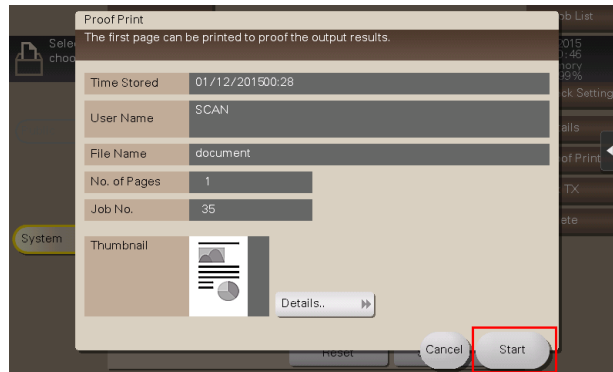

Printing starts.

4.4 Organize Faxes in a User Box

Operation flow

- 1 Tap [User Box].

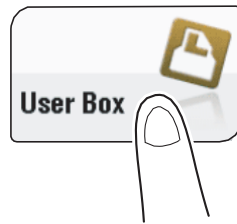

- 2 Tap [System] - [File Re-TX].

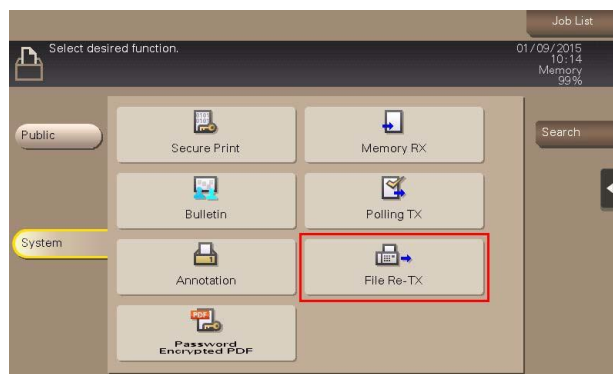

- 3 Select a file and set the desired operation.

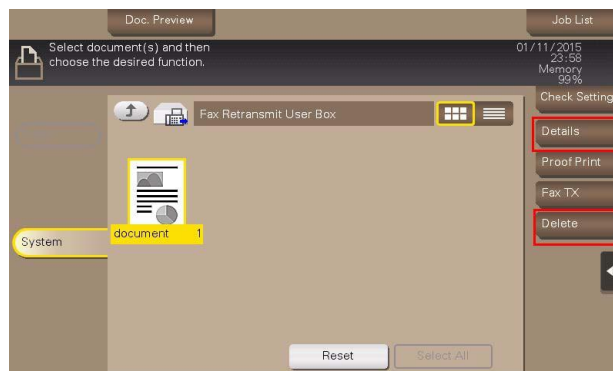

Delete a file

Select a file, then tap [Delete]. The file is deleted. You can also long-tap the target file to display the menu icon, then drag and drop it to  to get the same result.

You can select multiple files and delete them simultaneously. Check the file details, then tap [Yes].

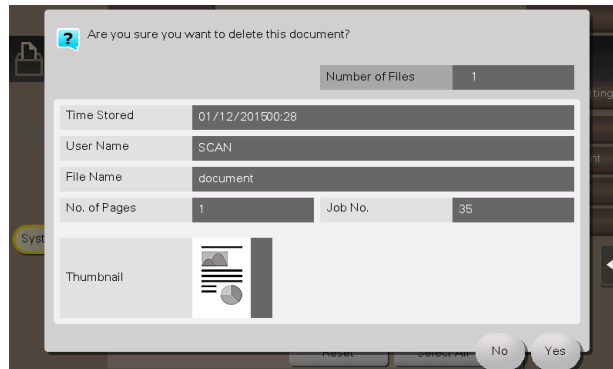

Check the file information

Select a file, then tap [Details] to check the detailed file information.

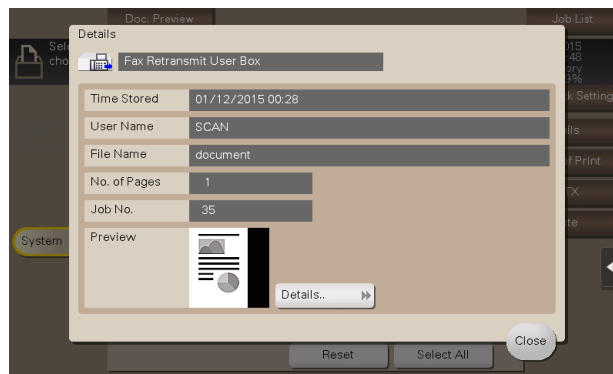

You can tap [Details..] or a thumbnail image to preview the file image.

If you tap the tab key on the right of the screen, you can display or hide the Setting Key. The Setting Key allows you to enlarge or reduce a preview image.

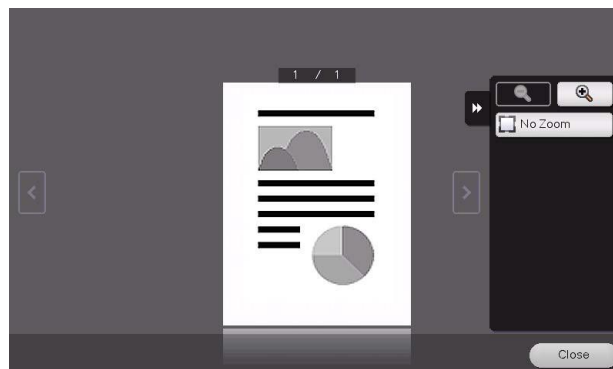



**Print Classified Documents
([Secure Print])**

5 Print Classified Documents ([Secure Print])

5.1 [Secure Print]

When you print a document from the PC or when you select the Secure Print function using the printer driver, this data file is stored in the Secure Print User Box. Once you have opened the User Box, you can select a file stored in the User Box and preview, print, rename, or delete it.

The document ID and password are required to print out the files stored in the Secure Print User Box. After the file has been printed out, it is deleted automatically. This box is used to handle classified documents.

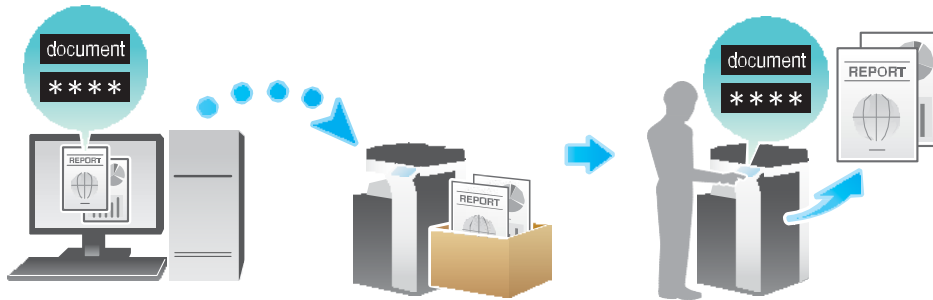

Tips

- The **Hard Disk** is optional in some areas. To use this function, the optional **Hard Disk** must be installed in this machine.

Related setting

- If you often use the Secure Print User Box, it will be useful to place its shortcut key on the top screen. For details, refer to "User's Guide[Descriptions of Functions/Utility Keys]/[Utility]".

Related setting (for the administrator)

- You can delete all files from the Secure Print User Box. For details, refer to "User's Guide[Descriptions of Functions/Utility Keys]/[Utility]".
- You can set a time to delete files automatically from the Secure Print User Box (Default: [1 day]). For details, refer to "User's Guide[Descriptions of Functions/Utility Keys]/[Utility]".

5.2 Print Files in a User Box

Print (basic operation flow)

- 1 Tap [User Box].

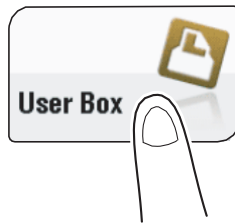

- 2 Tap [System] - [Secure Print].

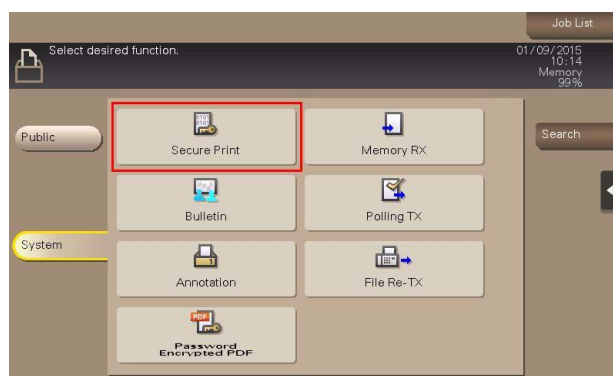

- 3 Enter the [Document ID] and [Password] for the secure document, then tap [OK].
Secure documents that have specified document IDs and password are listed.

- 4 Select a file to print, then tap [Print].

→ You can also long-tap the target file to display the menu icon, then drag and drop it to to get the same result.

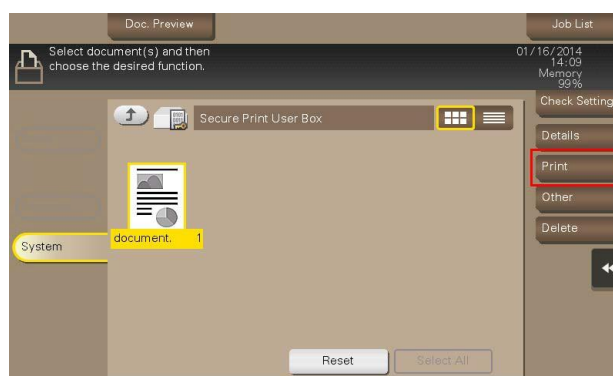

- 5 Set print options if necessary.

→ If an output image cannot be displayed, [Preview on Screen] appears. To check an output image, tap [Preview on Screen], then confirm the target output image on the preview window.

→ For detailed optional settings, refer to page 13-13.

- 6 Press the **Start** key.
Printing starts.



Print (If [Prohibited Functions When Authentication Error] is set to [Mode 2])

If the [Prohibited Functions When Authentication Error] is set to [Mode 2], you need to enter the password to select a file from the Secure Print User Box. You need to enter password for each file even if secure documents have the same document ID. Therefore, the security level is higher than that of default [Mode 1]. For details on [Prohibited Functions When Authentication Error], refer to "User's Guide[Descriptions of Functions/Utility Keys]/[Utility]".

- 1 Tap [User Box].

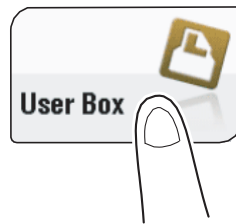

- 2 Tap [System] - [Secure Print].

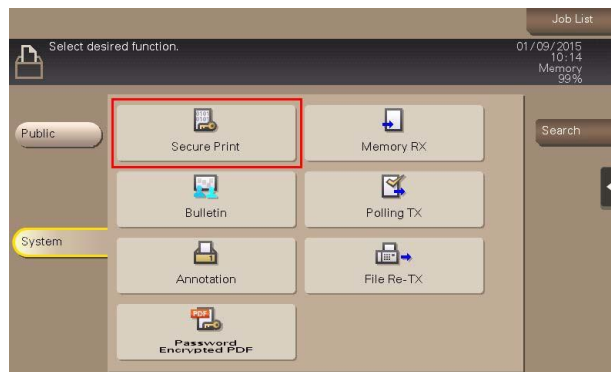

- 3 Enter the [Document ID] for the secure print document, then tap [OK].
Secure documents that have the specified document ID are listed.



- 4 Select a file to print, then tap [Other] - [Enter Password].

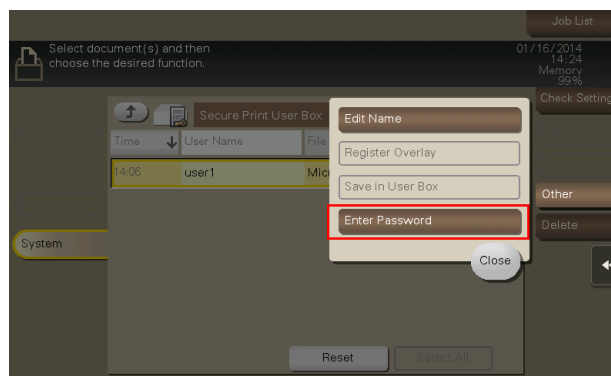

- 5 Enter the password for the secure print document, and then tap [OK].
The list of secure print documents matching the specified password appears.

→ If the user cannot enter the correct password within the number of times being set by the password administrator, the selected file is locked out. To release the operation prohibition status, contact your administrator.

- 6 Tap [Print].

→ You can also long-tap the target file to display the menu icon, then drag and drop it to  to get the same result.

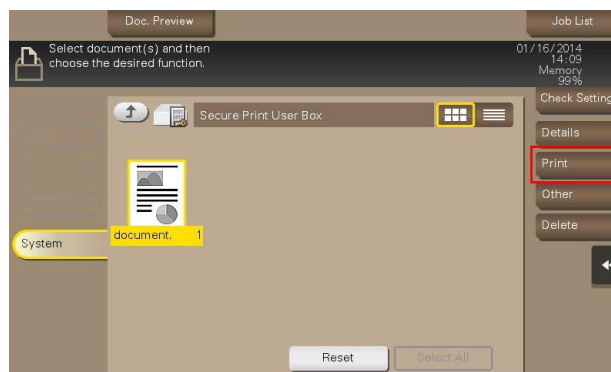

- 7 Set print options if necessary.

→ If an output image cannot be displayed, [Preview on Screen] appears. To check an output image, tap [Preview on Screen], then confirm the target output image on the preview window.

→ For detailed optional settings, refer to page 13-13.

- 8 Press the **Start** key.
Printing starts.



5.3 Organize Files in a User Box

Operation flow

In the following example, [Prohibited Functions When Authentication Error] function has been set to [Mode 1].

- 1 Tap [User Box].



- 2 Tap [System] - [Secure Print].

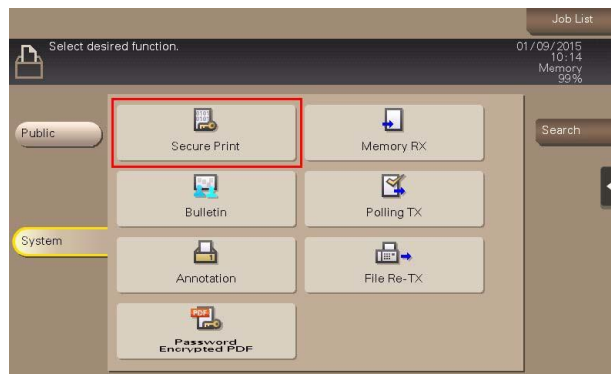

- 3 Enter the [Document ID] and [Password] for the secure document, then tap [OK].
Secure documents that have specified document IDs and password are listed.

- 4 Select a file and set the desired operation.

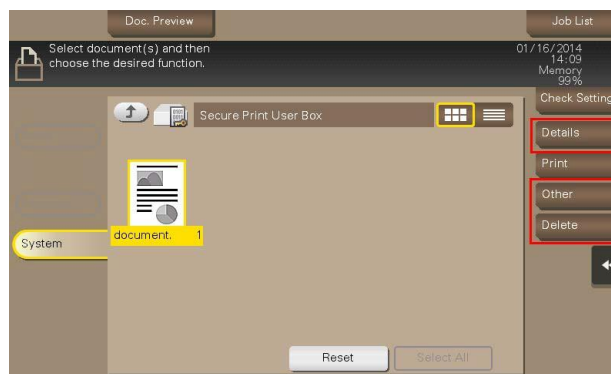

Delete a file

Select a file, then tap [Delete]. The file is deleted. You can also long-tap the target file to display the menu icon, then drag and drop it to  to get the same result.

You can select multiple files and delete them simultaneously. Check the file details, then tap [Yes].

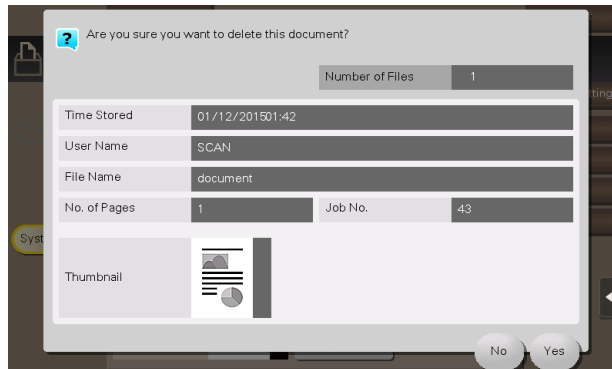

Rename a file

Select a file, then tap [Other] - [Edit Name]. Now you can rename the file. Enter a new name from the **Touch Panel**.



Tips

- Before renaming a file, check the destination server conditions and others.
- You can also rename a file while it is being transmitted.

Check the file information

Select a file, then tap [Details] to check the detailed file information.

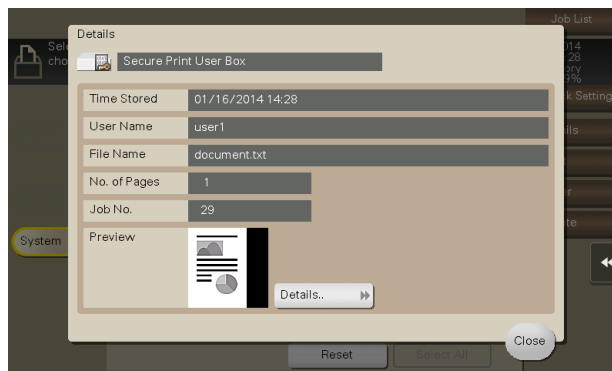

You can tap [Details..] or a thumbnail image to preview the file image.

If you tap the tab key on the right of the screen, you can display or hide the Setting Key. The Setting Key allows you to enlarge or reduce a preview image.

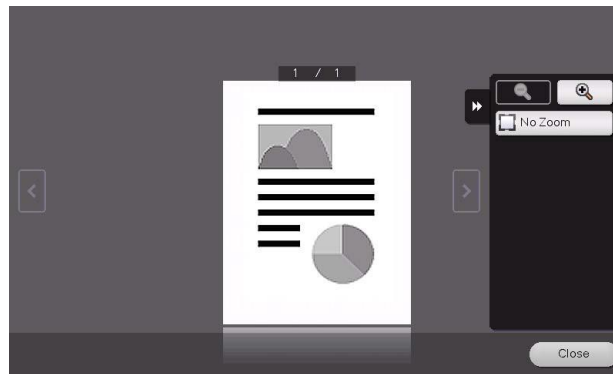



Annotate Files ([Annotation])

6 Annotate Files ([Annotation])

6.1 [Annotation]

When a stored file is printed out or sent to another user, its date, time and any annotations are added to this box automatically. Once you have opened the User Box, you can select a file stored in the User Box and preview, print out, send, rename, or delete it.

When a file is read from the Annotation User Box and used for printouts or transmitted to a recipient, the date, time and any annotations (previously determined for management) are automatically added to the header or footer of each image. You can prevent the unauthorized use of documents by creating a document that can identify the creation date and time and serial page number of each document.

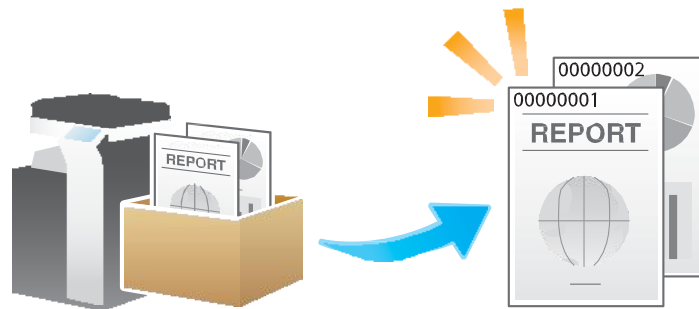

Tips

- This function is available when the Web browser function is disabled. When the optional **Extension Memory** is installed, this function is available regardless of whether the Web browser function is enabled or disabled.
- The **Hard Disk** is optional in some areas. To use this function, the optional **Hard Disk** must be installed in this machine.

Related setting

- If you often use the Annotation User Box, it will be useful to place its shortcut key on the top screen. For details, refer to "User's Guide[Descriptions of Functions/Utility Keys]/[Utility]".

6.2 Create an Annotation User Box

Only the administrator can create an Annotation User Box.

- 1 Tap [Utility] - [Administrator Settings] - [One-Touch/User Box Registration] - [Create User Box] - [Annotation User Box] - [New].
- 2 Enter the registration information, then tap [OK].
 - For details on registration information, refer to "User's Guide[Descriptions of Functions/Utility Keys]/[Utility]".

⦿ Reference

You can also create an Annotation User Box with the **Web Connection**. For details, refer to "User's Guide[Web Management Tool]/[Configuring the User Box Environment]".

6.3 Save File in a User Box

Save (basic operation flow)

- 1 Load the original.

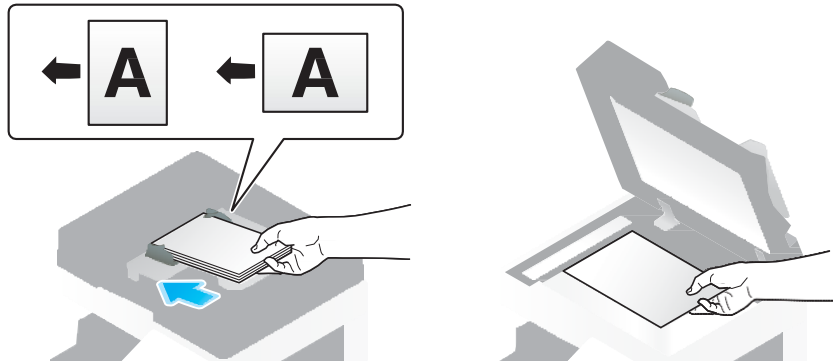

- 2 Tap [User Box].



- 3 Tap [System] - [Annotation].

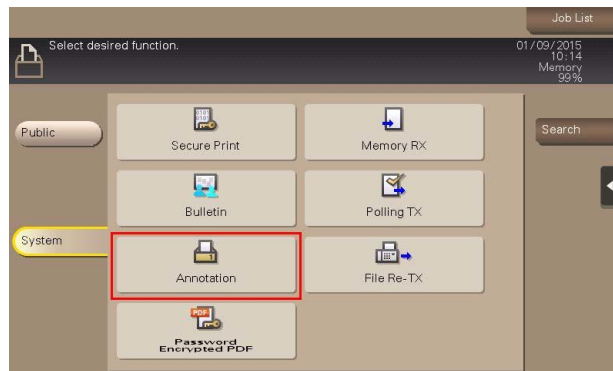

- 4 Select a User Box in which to save a file, then tap [Save].

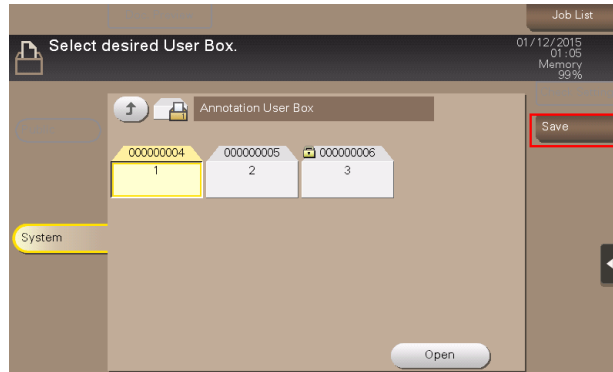

- 5 Set file save options if necessary.
→ For detailed optional settings, refer to page 13-2.

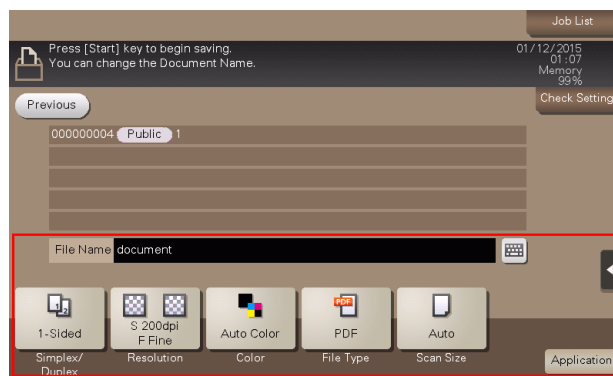

- 6 Press the **Start** key.
The file is saved.



Save files in Copy mode

You can read a document in Copy mode and save its data in the User Box.

For details, refer to "User's Guide[Copy Operations]/[Saving Original Images to a User Box]".

Save files from a PC

When specifying to print using the printer driver, you can specify a User Box number and store the print data in the box.

For details, refer to "User's Guide[Print Operations]/[Printing in the Windows Environment]".

6.4 Print Files in a User Box

- 1 Tap [User Box].



- 2 Tap [System] - [Annotation].

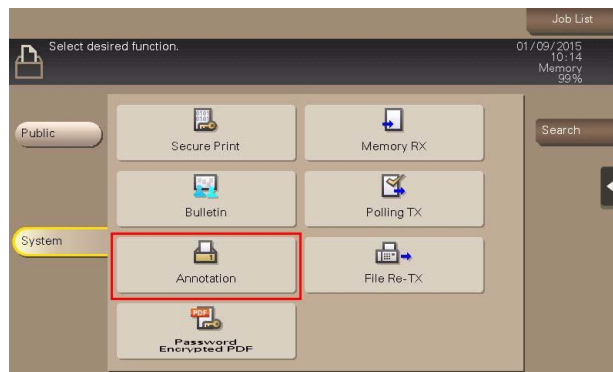

- 3 Select the desired User Box, then tap [Open].
 - If the box is password protected, tap [Open] and enter the password.
 - You can also open the desired User Box by tapping it twice.

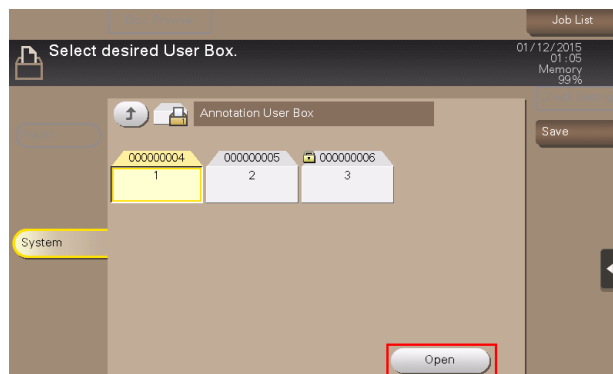

4 Select a file to print, then tap [Print].

→ You can also long-tap the target file to display the menu icon, then drag and drop it to  to get the same result.

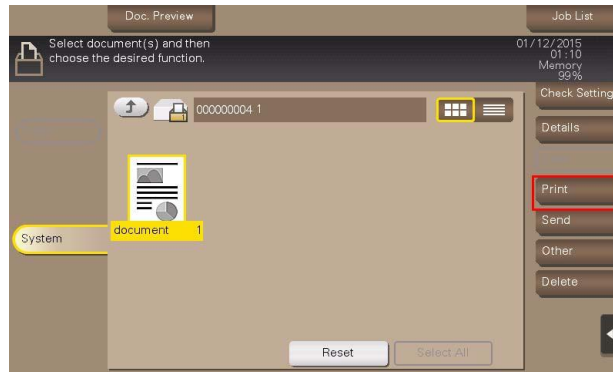

5 Set print options if necessary.

→ If an output image cannot be displayed, [Preview on Screen] appears. To check an output image, tap [Preview on Screen], then confirm the target output image on the preview window.

→ For detailed optional settings, refer to page 13-13.

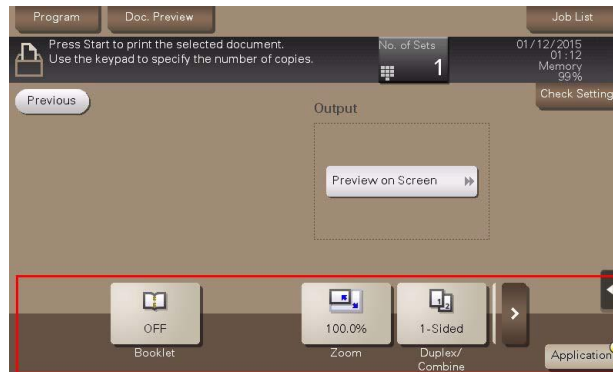

6 Press the **Start** key.

Printing starts.



 **Related setting (for the administrator)**

- You can specify to hold or clear a file from the box after file printing or sending (Default: [Yes]). Also, you can prompt the user to hold or not hold a file in the box after it has been printed or sent in the delete confirmation screen. For details, refer to "User's Guide[Descriptions of Functions/Utility Keys]/[Utility]".

6.5 Send Files in a User Box

6.5.1 Sending (Basic Operation Flow)

- 1 Tap [User Box].



- 2 Tap [System] - [Annotation].

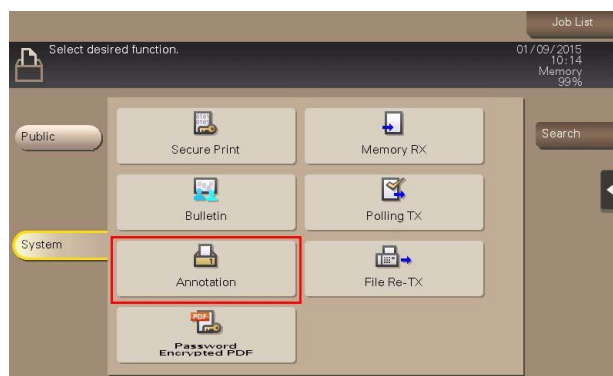

- 3 Select the desired User Box, then tap [Open].
 - If the box is password protected, tap [Open] and enter the password.
 - You can also open the desired User Box by tapping it twice.

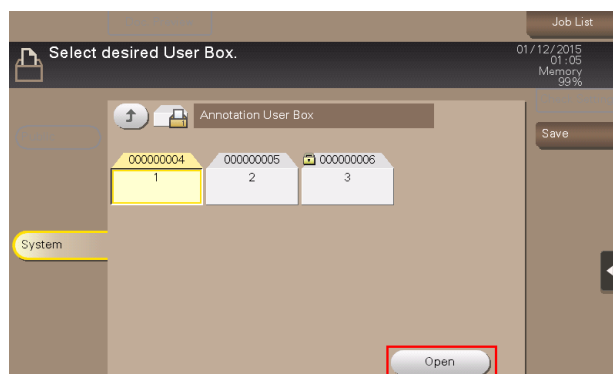

4 Select a file to send, then tap [Send].

→ You can also long-tap the target file to display the menu icon, then drag and drop it to  to get the same result.

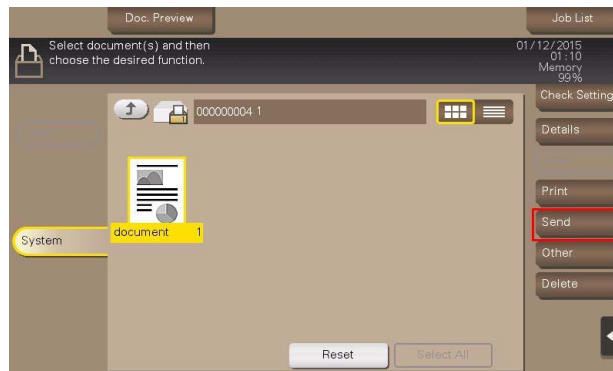

5 Specify the destination.

→ For the destination setup, refer to page 6-10.

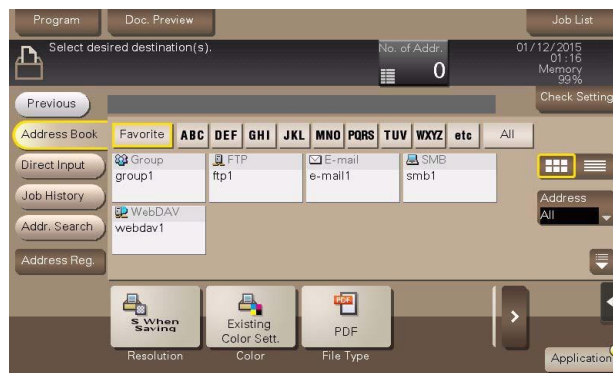

6 Set the file send options if necessary.

→ For detailed optional settings, refer to page 13-26.

→ You can change the file annotation if necessary. For details, refer to page 13-32.

7 Press the **Start** key.

Transmission begins.



 **Related setting (for the administrator)**

- You can specify to hold or clear a file from the box after file printing or sending (Default: [Yes]). Also, you can prompt the user to hold or not hold a file in the box after it has been printed or sent in the delete confirmation screen. For details, refer to "User's Guide[Descriptions of Functions/Utility Keys]/[Utility]".

6.5.2 Set a Destination

Selecting from address book

In [Address Book], select the destination registered on this machine.

You can send data by broadcast transmission if you select multiple destinations. You can also use broadcast transmission by combining different sending modes such as Scan to E-mail and SMB Send.

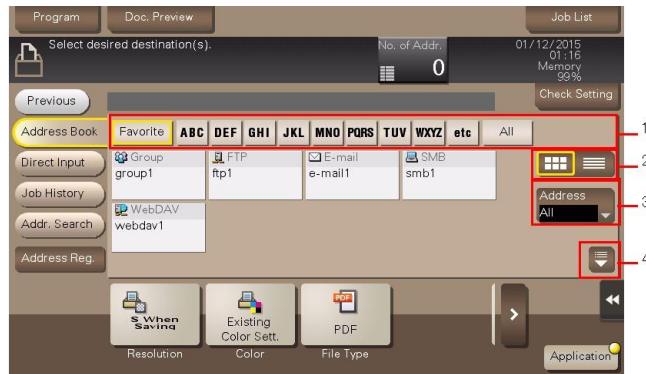

No.	Description
1	Narrow down destinations with the index specified for the registered destination. Using [Address] in combination further narrows down destinations. The following keys can be used to narrow down destinations: <ul style="list-style-type: none"> • [All]: All address book entries registered on this machine are displayed. • [Favorite]: The destinations specified with [Favorite] as search text are displayed. • [etc]: Displays destinations for which the registered name of each begins with a character other than an alphabet character.
2	Switches the display of the registered destinations to the button or list view mode. If the list view mode is selected, you can sort destinations by registration number, destination type, or registered name.
3	Narrow down destinations by the type of the registered destination. Using also search text further narrows down destinations.
4	Expands the area when scrolling is required in the area where the registered destinations are displayed.

Searching for destinations

If a large number of destinations are registered, you can search for a destination by registration name or destination (E-mail address or PC name).

- 1 Tap [Addr. Search] - [Search] - [Name Search] or [Address Search].
 - When searching for a destination by registration name, tap [Name Search].
 - When searching for a destination by E-mail address or computer name, tap [Address Search].
- 2 Enter the text you want to search for, then tap [Search].
- 3 Select a destination from the search result.

Direct input

In [Direct Input], tap the destination type key and enter the destination name.

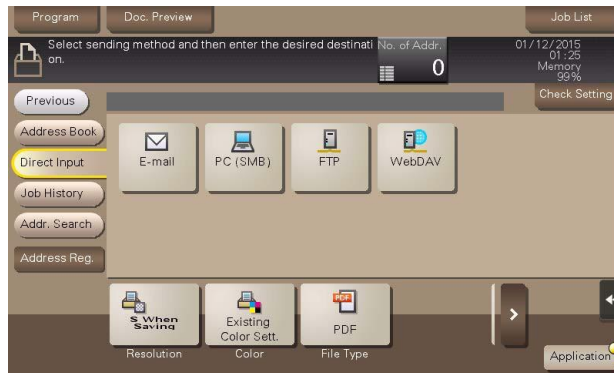

Purpose	Reference
To send e-mail with an attached file	"User's Guide[Descriptions of Functions/Utility Keys]/[Scan/Fax]"
To send data to a shared folder of a computer or server	"User's Guide[Descriptions of Functions/Utility Keys]/[Scan/Fax]"
To send data to the FTP server	"User's Guide[Descriptions of Functions/Utility Keys]/[Scan/Fax]"
To send data to the WebDAV server	"User's Guide[Descriptions of Functions/Utility Keys]/[Scan/Fax]"

⌚ Reference

You can register the destination that you have entered directly into the address book. For details on how to register it, refer to "User's Guide[Scan Operations]/[Managing Destinations]".

Select file from the history

Tap [Job History], and you can select a destination from the scan or saved job history.

The latest jobs (up to five) are displayed for history purposes. You can also select multiple destinations from the history.

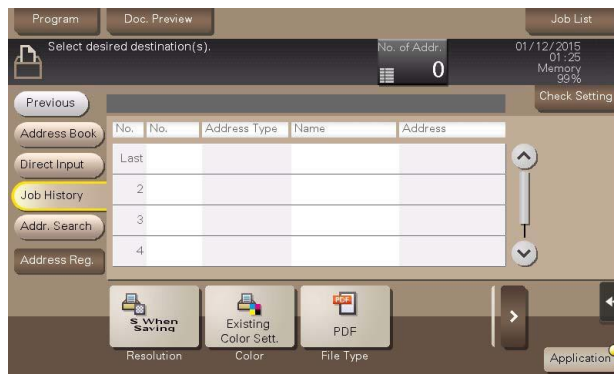

 **Tips**

- If you have edited a destination, you have edited a User Box, or you have turned the power supply Off and On again, the history data is deleted or lost.

Searching for an E-mail address through the LDAP server

If you are using the LDAP server or the Active Directory of Windows Server, you can search and select a mail address from the server.

- © To use the LDAP server or Active Directory to specify the destination, you must register the server on this machine. The registration procedure is explained using **Web Connection**. For details, refer to "User's Guide[Web Management Tool]/[Configuring the Scan Environment]".

- 1 Tap [Addr. Search] - [Search] - [Address Search (LDAP)] or [Adv. Search (LDAP)].
 - When searching using a single keyword, tap [Address Search (LDAP)].
 - When searching by combining keywords in different categories, tap [Adv. Search (LDAP)].
- 2 Enter the keyword, then tap [Search].
- 3 Select a destination from the search result.

6.6 Organize Files in a User Box

Operation flow

- 1 Tap [User Box].



- 2 Tap [System] - [Annotation].

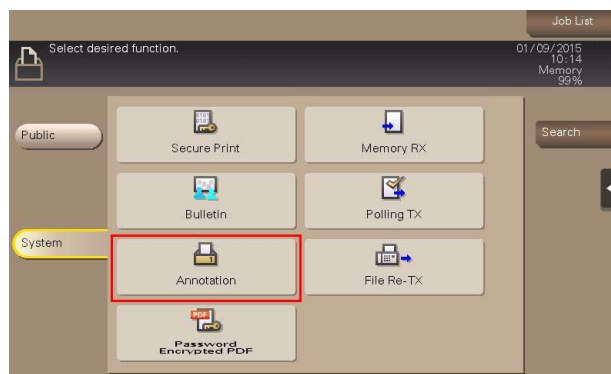

- 3 Select the desired User Box, then tap [Open].
 - If the box is password protected, tap [Open] and enter the password.
 - You can also open the desired User Box by tapping it twice.

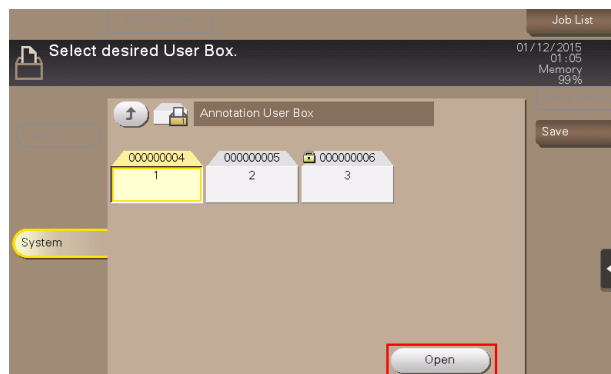

4 Select a file and set the desired operation.

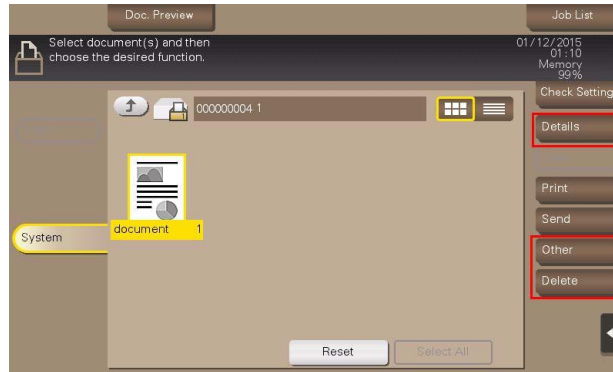

Delete a file

Select a file, then tap [Delete]. The file is deleted. You can also long-tap the target file to display the menu icon, then drag and drop it to  to get the same result.

You can select multiple files and delete them simultaneously. Check the file details, then tap [Yes].

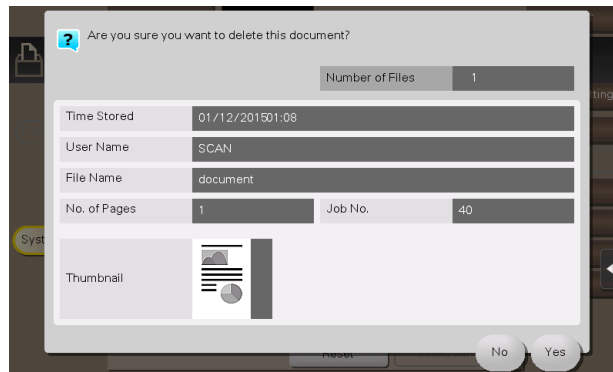

Rename a file

Select a file, then tap [Other] - [Edit Name]. Now you can rename the file. Enter a new name from the **Touch Panel**.

Tips

- Before renaming a file, check the destination server conditions and others.
- You can also rename a file while it is being transmitted.

Store file as an overlay image

Select a file, then tap [Other] - [Register Overlay]. Now you can store a file as an overlay image.

Once registered, you can compose an overlay image on the original during copy or printing from the PC. Also, you can compose an overlay image onto a User Box file during file printing.

You can register up to 100 overlay images.

- © This function is available when this machine is equipped with an optional **Extension Memory**.

- 1 To register an overlay image, select an unregistered key and tap [New].
 - To register an overlay image by overwriting an existing one, select the registered key and tap [Overwrite].

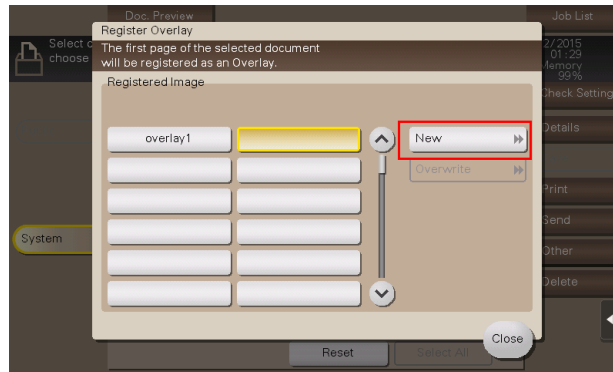

- 2 Enter a registration name, then tap [OK].
- 3 Set a density of image if necessary, then tap [Start].

Tips

- If a file consists of multiple pages, the first page is registered as an overlay image.
- Once registered, you can compose an overlay image on the original and copy it by selecting [Application] in Copy mode and [Registered Overlay]. Also, when you print a file from a User Box, you can compose an overlay image to the file and print it by selecting [Application] - [Registered Overlay].

Check the file information

Select a file, then tap [Details] to check the detailed file information.

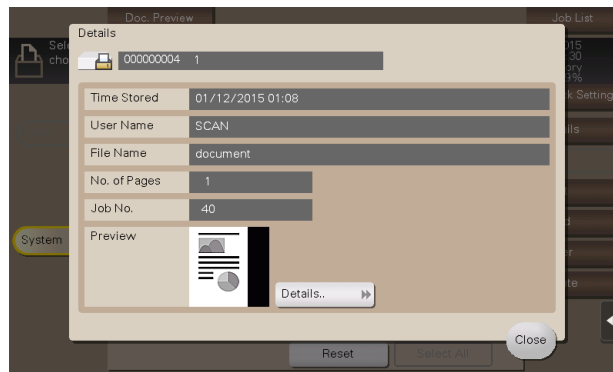

You can tap [Details..] or a thumbnail image to preview the file image.

If you tap the tab key on the right of the screen, you can display or hide the Setting Key. The Setting Key allows you to enlarge or reduce a preview image.

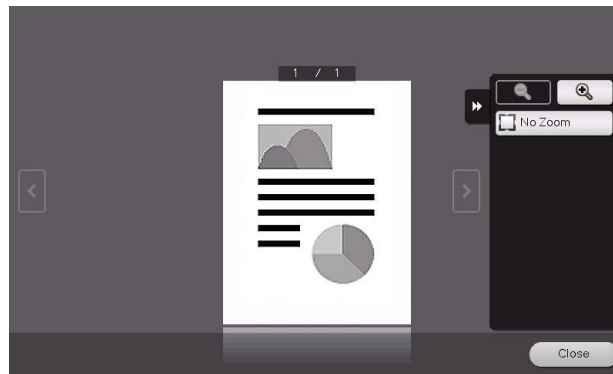



**Print an Encrypted PDF
([Password Encrypted PDF])**

7 Print an Encrypted PDF ([Password Encrypted PDF])

7.1 [Password Encrypted PDF]

When a password protected PDF file is printed out or stored in the User Box by using the Direct Print function or from USB memory, the file is stored in the Password Encrypted PDF User Box. Once you have opened the User Box, you can select a PDF file stored in the User Box to preview and print it out. Also, you can store the file in or delete it from the User Box.

When printing or saving a PDF file, you will need to enter a password that was set for the file.

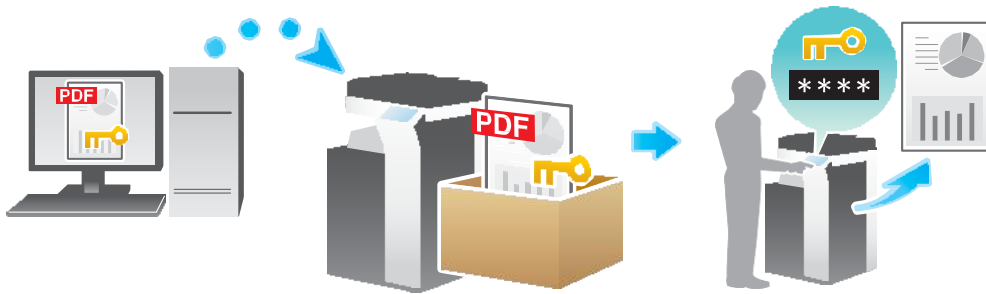

Tips

- The **Hard Disk** is optional in some areas. To use this function, the optional **Hard Disk** must be installed in this machine.
- If user authentication is enabled on this machine, only the password encrypted PDF data, which has been saved by the current login user, is displayed.

Related setting

- If you often use the Password Encrypted PDF User Box, it will be useful to place its shortcut key on the top screen. For details, refer to "User's Guide[Descriptions of Functions/Utility Keys]/[Utility]".

7.2 Store File in User Box, or Print File from User Box

- 1 Tap [User Box].



- 2 Tap [System] - [Password Encrypted PDF].

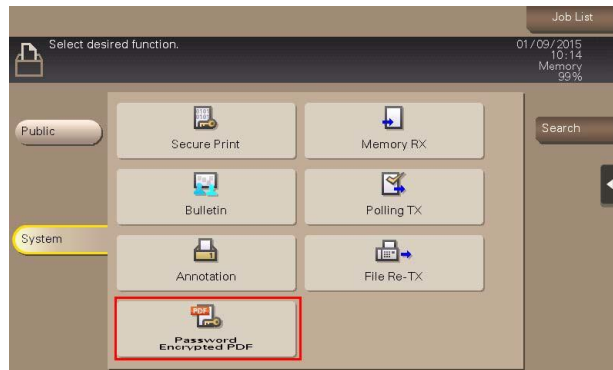

- 3 Select a file to print, then tap [Print/Save].

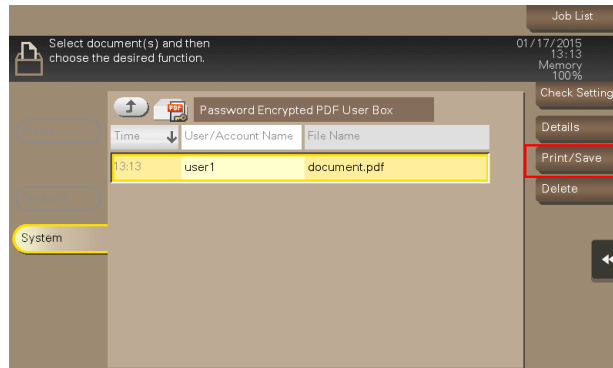

- 4 Enter the password, then tap [OK].
Printing starts.

Tips

- When printing or saving has completed, the file is deleted automatically from the Password Encrypted PDF User Box.
- The storage and printing process of the file is set when it is saved in the Password Encrypted PDF User Box. You cannot change from the storage process to the print process, or from the print process to the storage process.

7.3 Organize Files in a User Box

Operation flow

- 1 Tap [User Box].

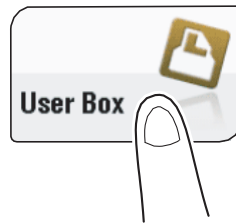

- 2 Tap [System] - [Password Encrypted PDF].

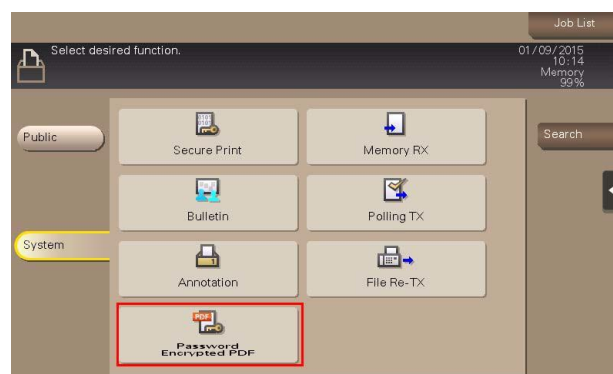

- 3 Select a file and set the desired operation.

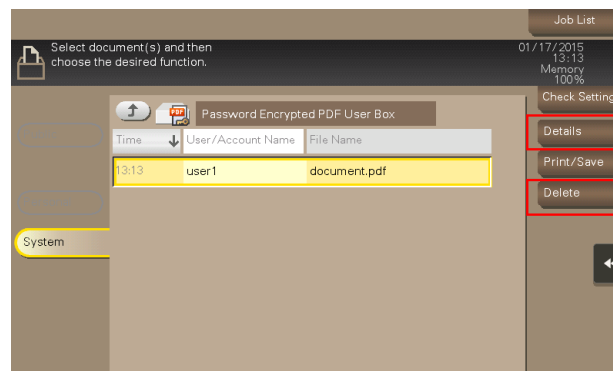

Delete a file

Select a file, then tap [Delete]. The file is deleted. You can select multiple files and delete them simultaneously. Check the file details, then tap [Yes].

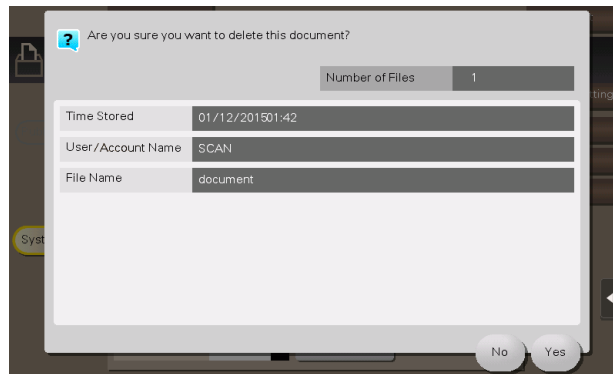

Check the file information

Select a file, then tap [Details] to check the detailed file information.

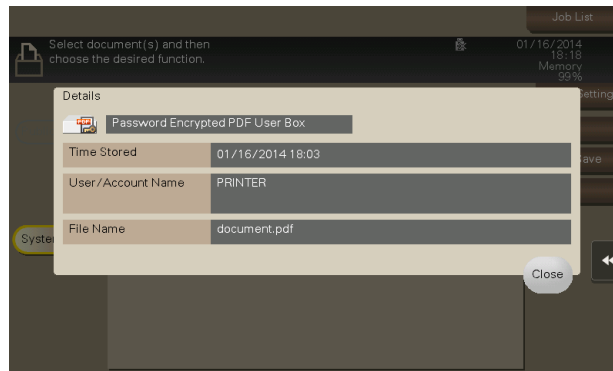



Registering a File for Polling ([Polling TX])

8 Registering a File for Polling ([Polling TX])

8.1 [Polling TX]

The fax documents required for polling are stored in the Polling Transmission User Box. Once you have opened the User Box, you can select a fax document stored in the User Box and preview, print out, or delete it.

If the fax documents are stored in the Polling TX User Box, recipients can be polled and receive fax documents from this box when necessary.

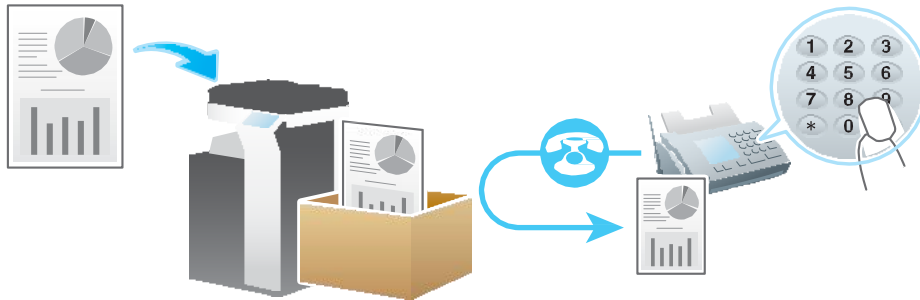

Tips

- The **Hard Disk** is optional in some areas. To use this function, the optional **Hard Disk** and **Fax Kit** must be installed in this machine.
- The Polling TX User Box can have only one file.
- If you have already stored a file and you need to store a new file in the Polling TX User Box, you must delete the existing file and store the new one.

Related setting

- If you often use the Polling TX User Box, it will be useful to place its shortcut key on the top screen. For details, refer to "User's Guide[Descriptions of Functions/Utility Keys]/[Utility]".

8.2 Print Files in a User Box

You can print and check the file contents if necessary.

- 1 Tap [User Box].

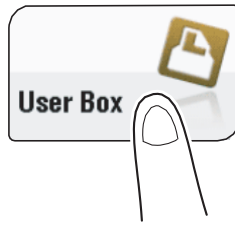

- 2 Tap [System] - [Polling TX].

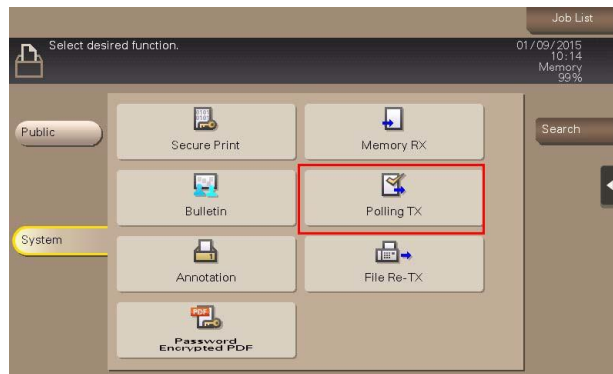

- 3 Tap [Print].

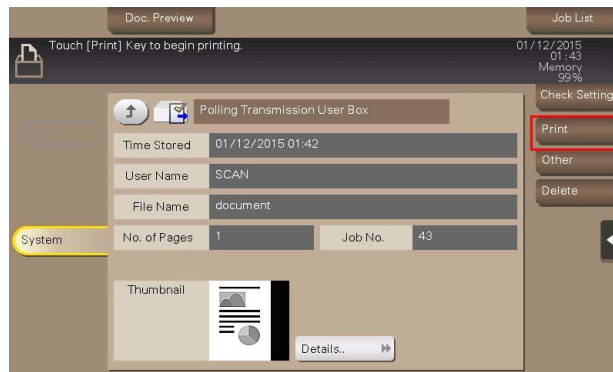

Printing starts.

8.3 Organize Files in a User Box

Operation flow

- 1 Tap [User Box].

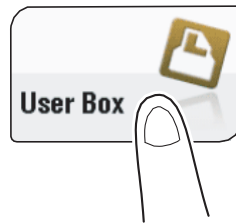

- 2 Tap [System] - [Polling TX].

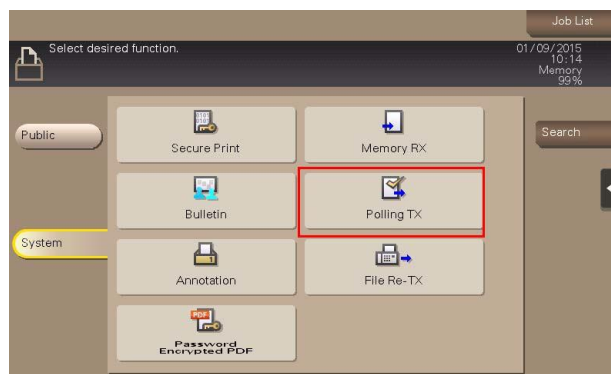

- 3 Set the desired operation.

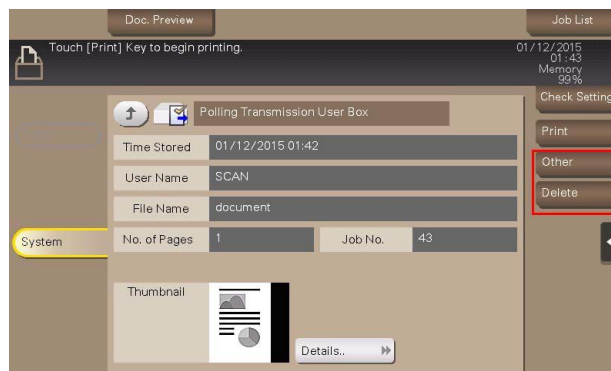

Delete a file

Select a file, then tap [Delete]. The file is deleted. You can select multiple files and delete them simultaneously. Check the file details, then tap [Yes].

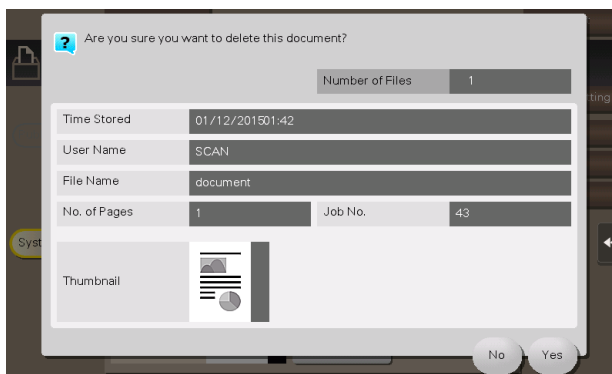

Store file as an overlay image

Select a file, then tap [Other] - [Register Overlay]. Now you can store a file as an overlay image.

Once registered, you can compose an overlay image on the original during copy or printing from the PC. Also, you can compose an overlay image onto a User Box file during file printing.

You can register up to 100 overlay images.

© This function is available when this machine is equipped with an optional **Extension Memory**.

1 To register an overlay image, select an unregistered key and tap [New].

→ To register an overlay image by overwriting an existing one, select the registered key and tap [Overwrite].

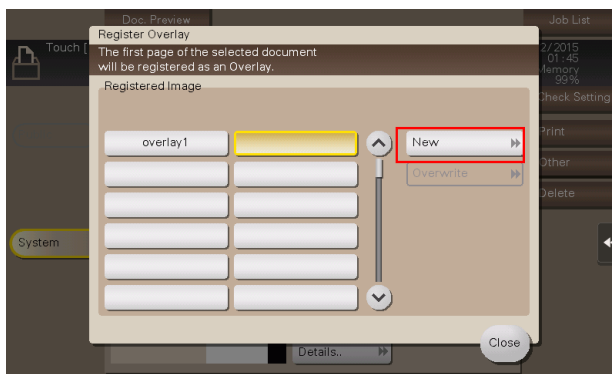

2 Enter a registration name, then tap [OK].

3 Set a density of image if necessary, then tap [Start].

Tips

- If a file consists of multiple pages, the first page is registered as an overlay image.
- Once registered, you can compose an overlay image on the original and copy it by selecting [Application] in Copy mode and [Registered Overlay]. Also, when you print a file from a User Box, you can compose an overlay image to the file and print it by selecting [Application] - [Registered Overlay].

Check the file information

You can tap [Details..] or a thumbnail image to preview the file image.

If you tap the tab key on the right of the screen, you can display or hide the Setting Key. The Setting Key allows you to enlarge or reduce a preview image.

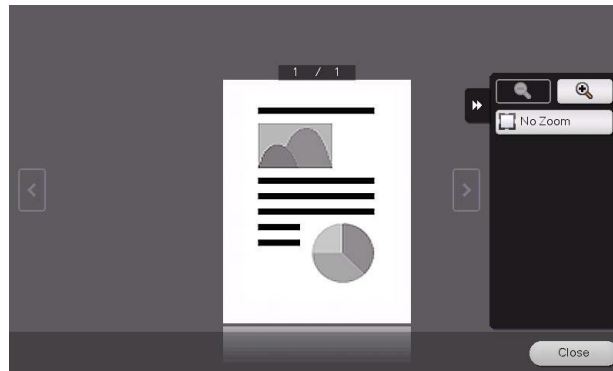



**Store File for Polling
([Bulletin])**

9 Store File for Polling ([Bulletin])

9.1 [Bulletin]

Multiple fax documents required for polling can be stored in the Bulletin Board User Box.

You can create and register up to 10 Bulletin Board User Boxes. Once you have opened the User Box, you can select a fax document stored in the User Box and preview, print out, or delete it.

If announcement and other fax documents are stored in Bulletin Board User Boxes by purpose and if recipients are notified with the relating box numbers, the users can select the required fax documents and they can be polled.

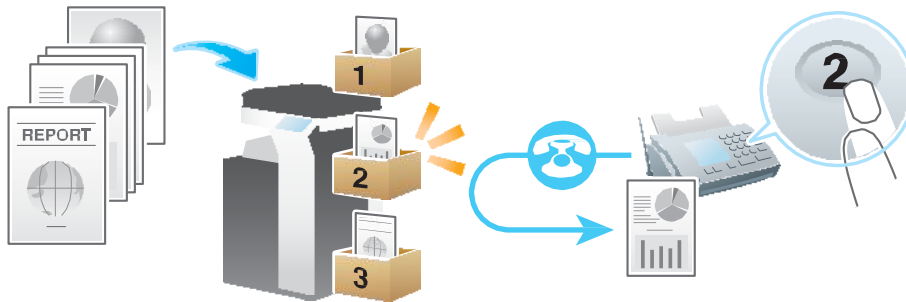

Tips

- The **Hard Disk** is optional in some areas. To use this function, the optional **Hard Disk** and **Fax Kit** must be installed in this machine.
- The Bulletin Board User Box can only contain one file.
- If you have already stored a file and you need to store a new file in the Bulletin Board User Box, you must delete the existing file and store the new one.

Related setting

- If you often use the Bulletin Board User Box, it will be useful to place its shortcut key on the top screen. For details, refer to "User's Guide[Descriptions of Functions/Utility Keys]/[Utility]".

9.2 Create Bulletin Board User Box

Up to 10 Bulletin Board User Boxes can be created.

- 1 Tap [Utility] - [One-Touch/User Box Registration] - [Create User Box] - [Bulletin Board User Box] - [New].
→ The administrator can perform the same actions by selecting [Administrator Settings] - [One-Touch/User Box Registration].
- 2 Enter the registration information, then tap [OK].
→ For details on registration information, refer to "User's Guide[Descriptions of Functions/Utility Keys]/[Utility]".

ⓘ Reference

You can also register the box using **Web Connection**. For details, refer to "User's Guide[Web Management Tool]/[Configuring the User Box Environment]".

9.3 Print Files in a User Box

You can print and check the file contents if necessary.

- 1 Tap [User Box].

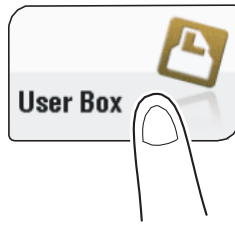

- 2 Tap [System] - [Bulletin].

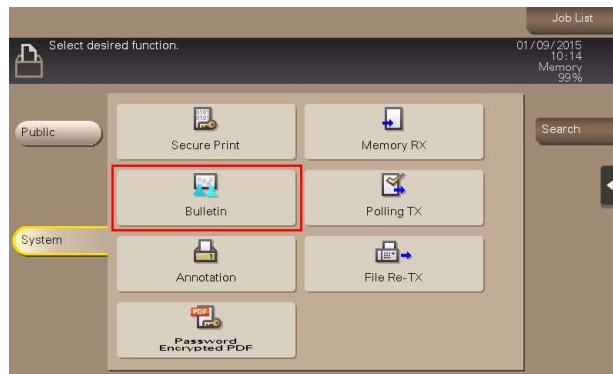

- 3 Select the desired User Box, then tap [Open].
 - If the box is password protected, tap [Open] and enter the password.
 - You can also open the desired User Box by tapping it twice.

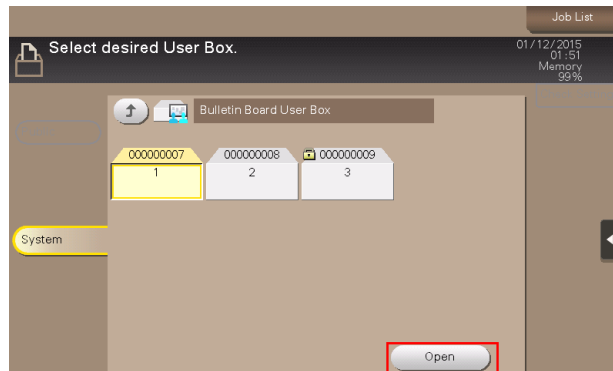

4 Tap [Print].

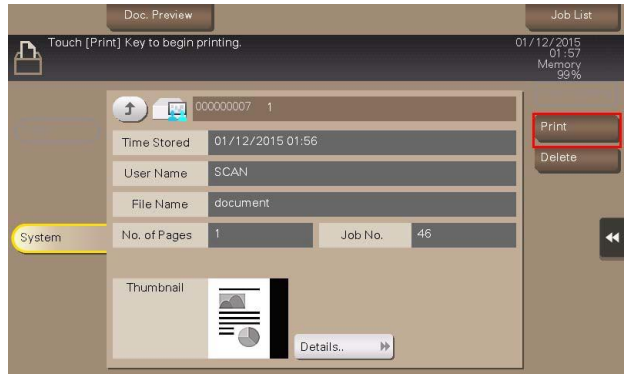

Printing starts.

9.4 Organize Files in a User Box

Operation flow

- 1 Tap [User Box].



- 2 Tap [System] - [Bulletin].

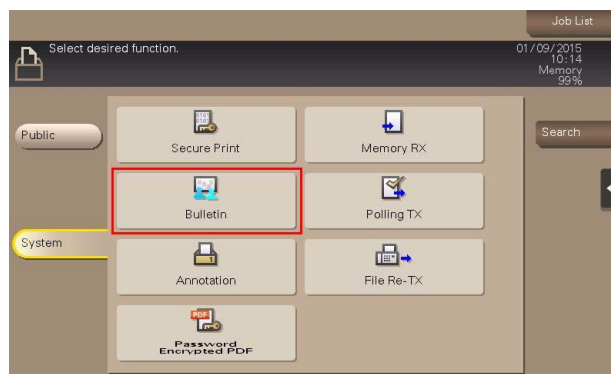

- 3 Select the desired User Box, then tap [Open].
 - If the box is password protected, tap [Open] and enter the password.
 - You can also open the desired User Box by tapping it twice.

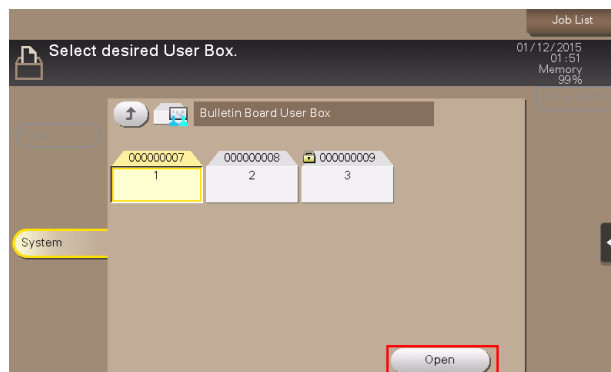

4 Set the desired operation.

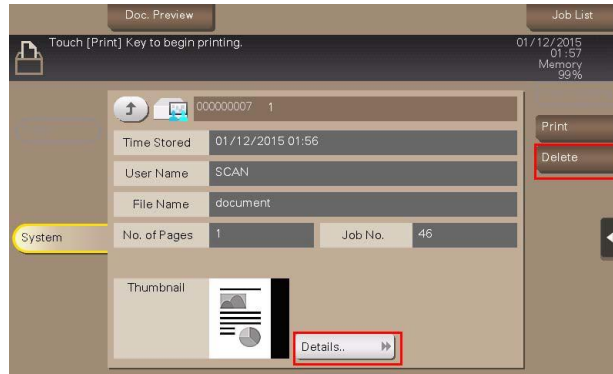

Delete a file

Select a file, then tap [Delete]. The file is deleted. You can select multiple files and delete them simultaneously. Check the file details, then tap [Yes].

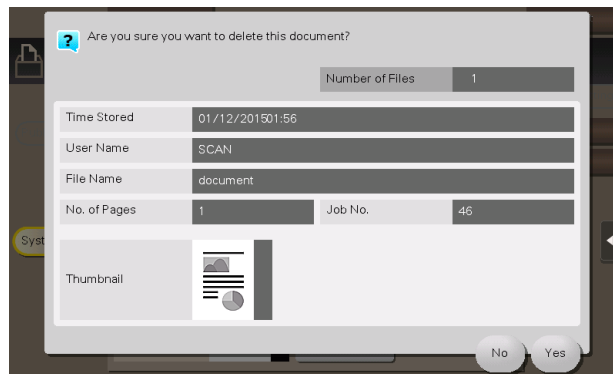

Check the file information

You can tap [Details..] or a thumbnail image to preview the file image.

If you tap the tab key on the right of the screen, you can display or hide the Setting Key. The Setting Key allows you to enlarge or reduce a preview image.

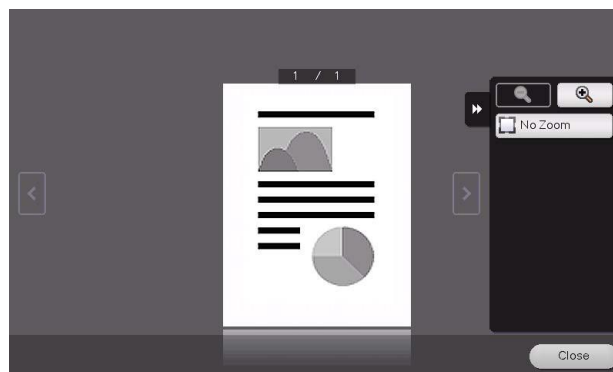

10

**Use as Fax Transponder
([Relay User Box])**

10 Use as Fax Transponder ([Relay User Box])

10.1 [Relay User Box]

When you use this machine as a relay machine to the facsimile, the Relay User Box is used for data relay.

If you use the Relay Distribution and when you send a fax to the relay machine, it distributes the fax to all recipients being registered in the Relay User Box.

If you are using broadcasting to distant places, you can reduce the total communication cost by using the relay machine.

To use this machine as a relay machine to facsimile, you need to create a Relay User Box and set the recipients.

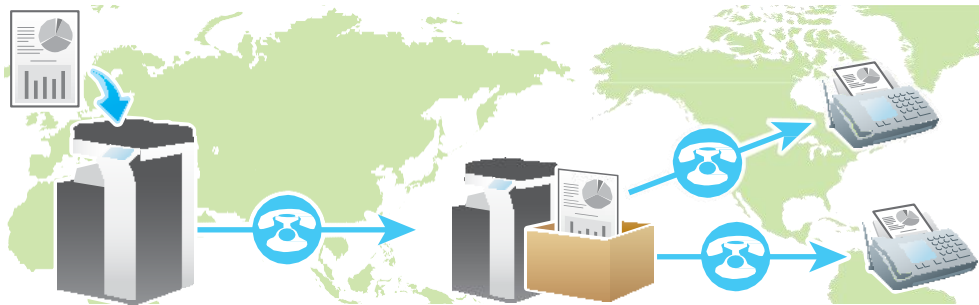

Tips

- The **Hard Disk** is optional in some areas. To use this function, the optional **Hard Disk** and **Fax Kit** must be installed in this machine.

Reference

This machine can request another relay machine to relay fax documents. For details on how to request a fax relay, refer to "User's Guide[Fax Operations]/[Sending Options]".

10.2 Operations Required to Use This Function

Register the fax recipients

To use this machine as a fax relay machine, register the fax recipients. Enter the recipients data in the Group User Box.

- ⦿ To register a group, you must register the one-touch destinations to be added to the group in advance. Register the fax recipients in the Address Book.

1 Tap [Utility] - [One-Touch/User Box Registration] - [Create One-Touch Destination] - [Group] - [New].
→ The administrator can perform the same actions by selecting [Administrator Settings] - [One-Touch/User Box Registration].

2 Enter destination information, then tap [OK].
→ For details on registration information, refer to "User's Guide[Descriptions of Functions/Utility Keys][Utility]".

⦿ Reference

You can also register groups using **Web Connection**. For details, refer to "User's Guide[Web Management Tool][Registering Various Types of Information]".

Create a Relay User Box

To use this machine as a fax relay machine, create a Relay User Box. Assign the Relay User Box the recipients you have registered on the Group Address List.

Up to five Relay User Boxes can be created.

1 Tap [Utility] - [One-Touch/User Box Registration] - [Create User Box] - [Relay User Box] - [New].
→ The administrator can perform the same actions by selecting [Administrator Settings] - [One-Touch/User Box Registration].

2 Enter the registration information, then tap [OK].
→ For details on registration information, refer to "User's Guide[Descriptions of Functions/Utility Keys][Utility]".

⦿ Reference

You can also register the Relay User Box using **Web Connection**. For details, refer to "User's Guide[Web Management Tool][Configuring the User Box Environment]".

11

**Print on MFP under
Authentication Control ([ID &
Print])**

11 Print on MFP under Authentication Control ([ID & Print])

11.1 [ID & Print]

When you print a document from the PC in the user authentication system environment, the files transferred with the ID & Print function are stored in the ID & Print User Box. When a user who has sent the print data logs in to this machine and opens the User Box, he can preview, print out, or delete the stored file.

Because user authentication is required in order to use a file, this box is useful for handling documents containing private information.

When authenticated is complete on the **Touch Panel**, the user can print out a file from the ID & Print User Box immediately. This allows quick and smooth operation as the user is not required to open the box and select a print file.

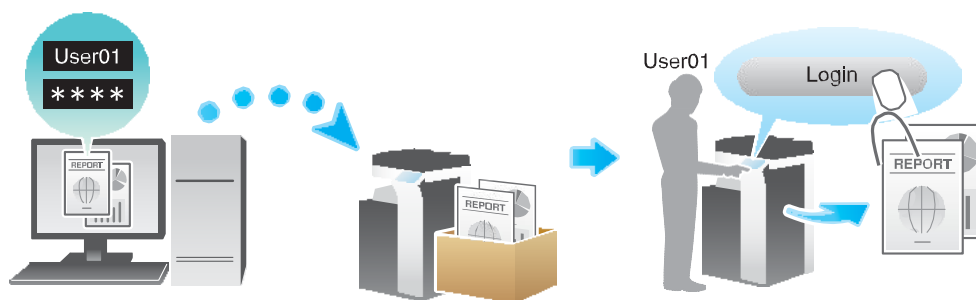

Tips

- The **Hard Disk** is optional in some areas. To use this function, the optional **Hard Disk** must be installed in this machine.

Related setting

- If you often use the ID & Print User Box, it will be useful to place its shortcut key on the top screen. For details, refer to "User's Guide[Descriptions of Functions/Utility Keys]/[Utility]".

Related setting (for the administrator)

- You can specify the action that this machine takes when the ID & Print function is used. For details, refer to "User's Guide[Descriptions of Functions/Utility Keys]/[Utility]".
- You can set a time to delete files automatically from the ID & Print User Box (Default: [1 day]). For details, refer to "User's Guide[Descriptions of Functions/Utility Keys]/[Utility]".
- Select whether to ask the user if they want to delete the file from the ID & Print User Box after it is printed or to always delete the file without making confirmation (Default: [Confirm with User]). For details, refer to "User's Guide[Descriptions of Functions/Utility Keys]/[Utility]".

11.2 Print Files in a User Box

The following explains how to print a file manually from the [ID & Print] User Box.

- 1 In the [ID & Print] subwindow, tap [Access Basic Screen].
 - Selecting [ID & Print/MFP Access] enables authenticating and also all the files of the corresponding users stored in ID & Print User Box to be printed, but does not allow to login this machine.

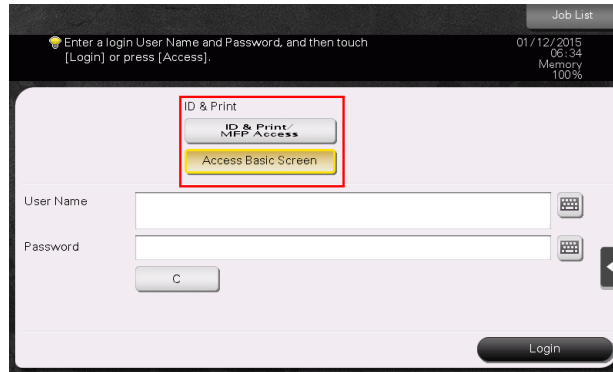

- 2 Tap the [User Name] field or keyboard icon, and enter the user name and password.
- 3 Tap [Login].
- 4 Tap [User Box].

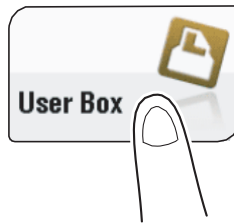

- 5 Tap [System] - [ID & Print].

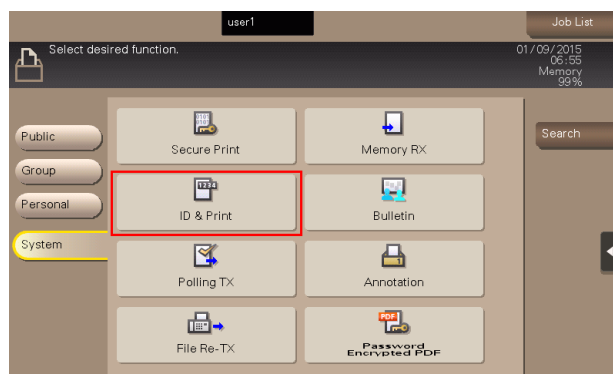

6 Select a file to print, then tap [Print].

→ You can also long-tap the target file to display the menu icon, then drag and drop it to  to get the same result.

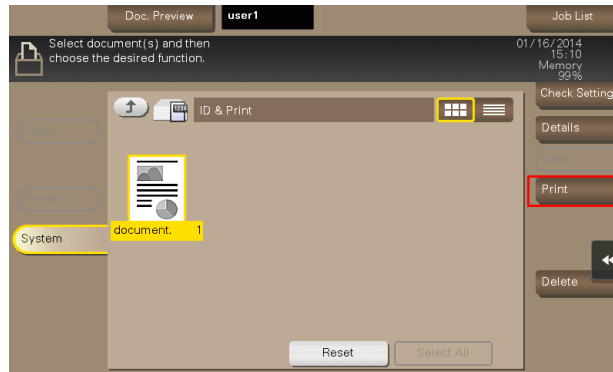
**7** Specify to leave the file in the User Box or delete the file from the User Box after you have printed it out.

→ If you tap [Yes], the file will be deleted after its printing.

→ If you tap [No], the file will be left in the User Box after its printing.

→ If you tap [Cancel], the current printing is canceled.

11.3 Organize Files in a User Box

Operation flow

- 1 In the [ID & Print] subwindow, tap [Access Basic Screen].
→ Selecting [ID & Print/MFP Access] enables authenticating and also all the files of the corresponding users stored in ID & Print User Box to be printed, but does not allow to login this machine.

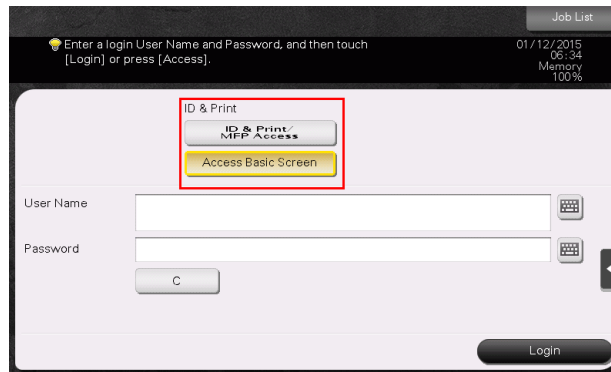

- 2 Tap the [User Name] field or keyboard icon, and enter the user name and password.
- 3 Tap [Login].
- 4 Tap [User Box].



- 5 Tap [System] - [ID & Print].

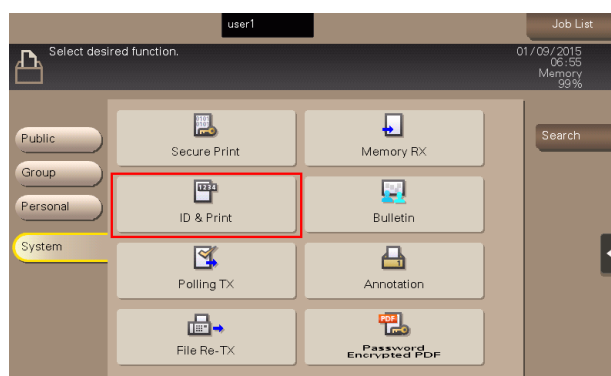

6 Select a file and set the desired operation.

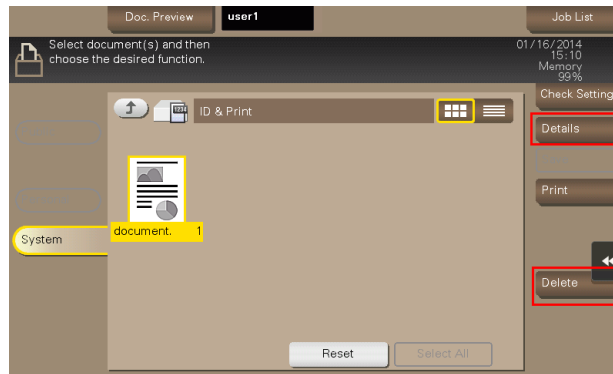

Delete a file

Select a file, then tap [Delete]. The file is deleted. You can also long-tap the target file to display the menu icon, then drag and drop it to  to get the same result.

You can select multiple files and delete them simultaneously. Check the file details, then tap [Yes].

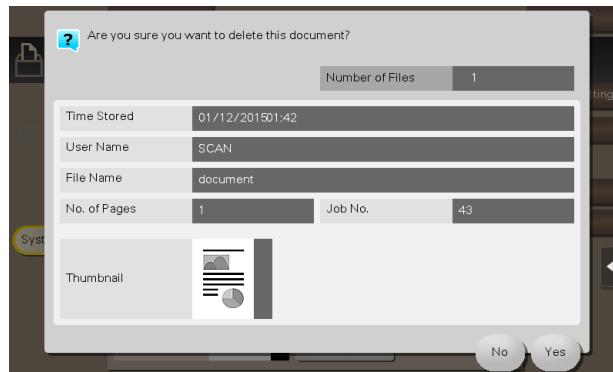

Check the file information

Select a file, then tap [Details] to check the detailed file information.

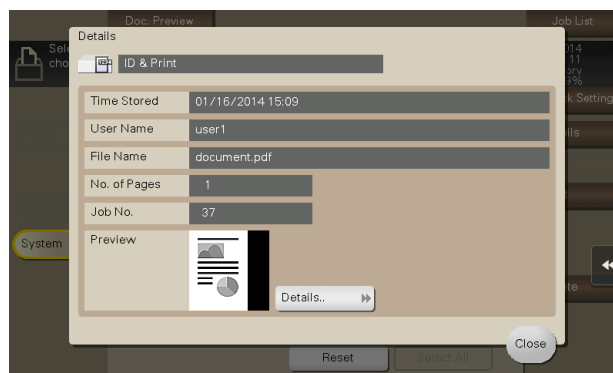

You can tap [Details..] or a thumbnail image to preview the file image.

If you tap the tab key on the right of the screen, you can display or hide the Setting Key. The Setting Key allows you to enlarge or reduce a preview image.

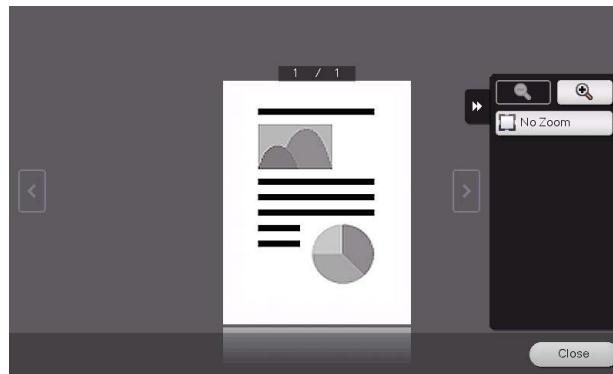

12

Use a USB Memory Device ([External Memory])

12 Use a USB Memory Device ([External Memory])

12.1 [External Memory]

This window appears when you insert a USB memory device into the USB port of this machine.

Once you have opened the User Box, you can print out a file stored on a USB memory. Also, you can read the original data and directly save it as a file in the USB memory. You can also move a file from the USB memory to the External Memory User Box.

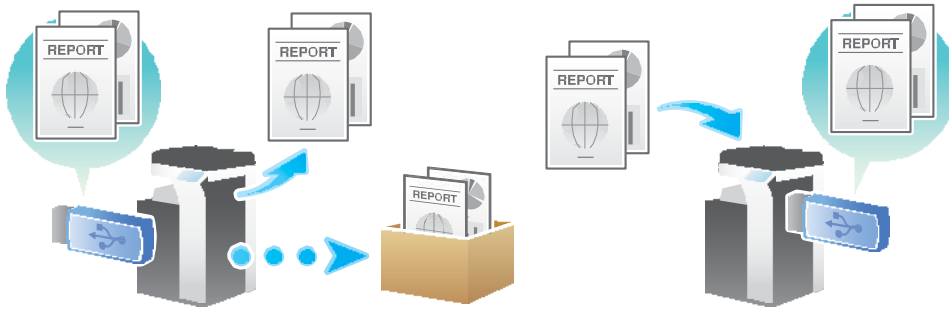

When you insert a USB memory device into the USB port of this machine, the [Information] screen appears to set a USB memory operation. You can use the USB memory immediately without selecting the User Box operation mode and without tapping the [System] - [External Memory] buttons.

Tips

- The **Hard Disk** is optional in some areas. To use this function, the optional **Hard Disk** must be installed in this machine.
- When you insert a USB memory device into the USB port of this machine, the USB memory icon appears at the top of the screen. When the USB memory is in the port, you can call the [Information] screen just by tapping this icon.

Related setting

- If you often use the [External Memory], it will be useful to place its shortcut key on the top screen. For details, refer to "User's Guide[Descriptions of Functions/Utility Keys]/[Utility]".

Related setting (for the administrator)

- The items displayed in the [Information] screen vary depending on the system settings for USB memory device operation. Storage of a file on a USB memory and reading of a file from a USB memory are both inhibited by default. For system settings for USB memory operation, refer to "User's Guide[Descriptions of Functions/Utility Keys]/[Utility]".
- If you are logging in as a User Box administrator with user authentication implemented, only [Print a document from External Memory.] appears.

12.2 Supported USB Memory Devices

USB memory devices that have the following specifications can be connected to this machine.

Item	Requirement
Interface	Compatible with USB Version 2.0/1.1 interface
Format	FAT32 format files
Security	Securities such as data encryption and password lock shall be released, or the security function shall be turned Off.
Memory size	No upper limit. <ul style="list-style-type: none">• Some USB memory devices may not be supported.• A USB memory device, which is recognized as multiple drives, cannot be used.

Note the following points when connecting a USB memory device to this machine.

- Use the USB connector on the side that is near the **Control Panel**.
- Do not disconnect the USB memory device while saving a file to the device or printing a file saved in the device.
- Do not use USB devices (such as hard disk unit and a USB switching hub) except for a USB memory.
- Do not connect or disconnect the USB memory when the hourglass is being displayed in the **Control Panel** while this machine is active.
- Do not disconnect the USB memory directly after connecting it.

12.3 Print a File from a USB Memory Device

Operations required to use this function (for the administrator)

Enable to print files from a USB memory.

As file printing is enabled by default, an operator can use USB memory on this machine without any setup.

For system settings for USB memory operation, refer to "User's Guide[Descriptions of Functions/Utility Keys]/[Utility]".

Operation flow

Any of PDF, Compact PDF, JPEG, TIFF, XPS, Compact XPS, OOXML (.docx/.xlsx/.pptx), and PPML (.ppml/.vdx/.zip) format files can be printed out.

Tips

- You can also print out encrypted PDF, searchable PDF, and outline PDF files.

- 1 Insert a USB memory device into the USB port of the machine.

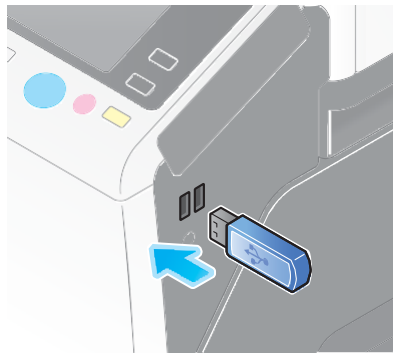

NOTICE

When this machine is starting up, do not insert or remove the USB memory device to/from the USB port.

- 2 Tap [Print a document from External Memory.].

→ You can also print files by selecting the User Box mode and by tapping [System] - [External Memory].

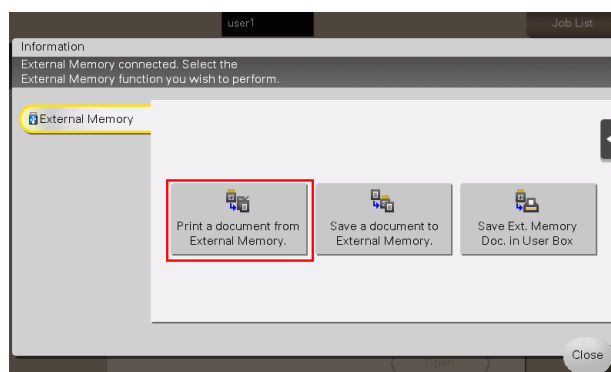

- 3 Select a file to print, then tap [Print].
 - You can directly enter the path to the file folder in the [File Path] field.
 - Tap [Top] to move upward.
 - Tap [Open] to open the folder and move downward.
 - Tap [Details] to display and check the detailed file information.

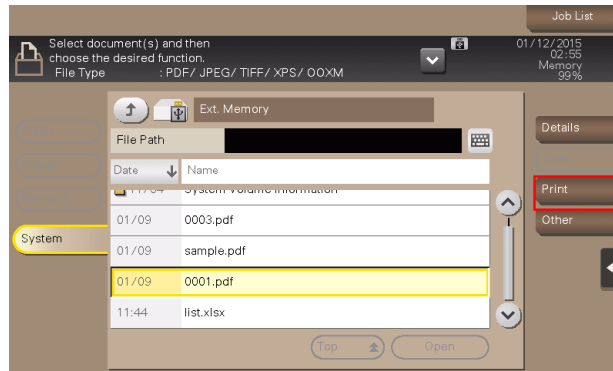

- 4 Set print options if necessary.
 - You can select a paper size for printing. For details, refer to page 13-13.
 - For detailed optional settings, refer to page 13-13.
- 5 Press the **Start** key.

Printing starts.



- 6 When printing is complete, remove the USB memory device from the port of this machine.

⌚ Reference

When you print a password protected PDF file, the file is stored in the Password Encrypted PDF User Box. To print files from Password Encrypted PDF User Box, refer to page 7-3.

12.4 Save Scanned Data on a USB Memory

Preparation required to use this function (for the administrator)

Enable to save files on a USB memory.

A file storage on a USB memory is disabled by default in order to prevent a data theft.

For system settings for USB memory operation, refer to "User's Guide[Descriptions of Functions/Utility Keys]/[Utility]".

Related setting (for the administrator)

- If user authentication has been implemented, you can set permissions for every registration user and public users to store files on a USB memory (Default: [Restrict]). For details, refer to "User's Guide[Descriptions of Functions/Utility Keys]/[Utility]".
- If you are logging in as a User Box administrator with user authentication implemented, you cannot save the scanned original data on a USB memory device.

Operation flow

- 1 Load the original.

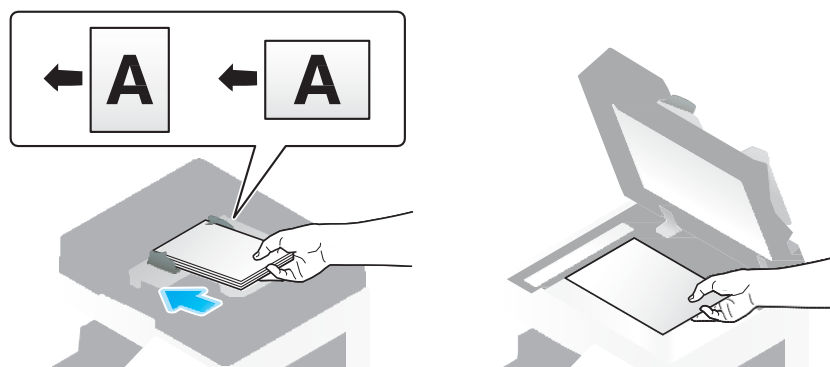

- 2 Insert a USB memory device into the USB port of the machine.

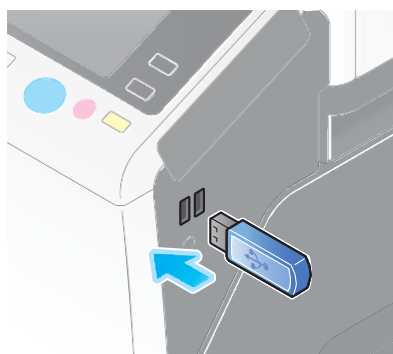

NOTICE

When this machine is starting up, do not insert or remove the USB memory device to/from the USB port.

- 3 Tap [Save a document to External Memory.].
→ You can also save files by selecting the User Box operation mode and by tapping [System] - [External Memory] - [Save].

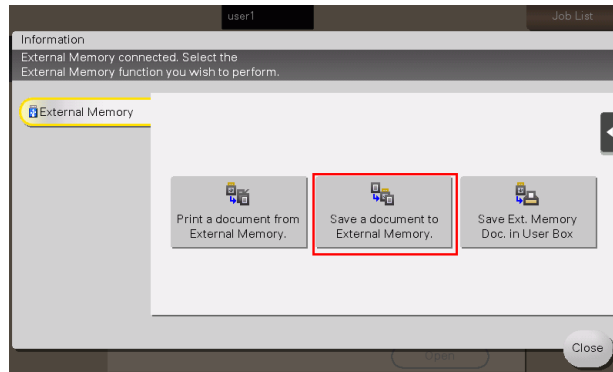

- 4 Set file save options if necessary.
→ For detailed optional settings, refer to page 13-2.
- 5 Press the **Start** key.
The file is saved.



- 6 When the operation is complete, remove the USB memory device from the port of this machine.
When you use files stored on the USB memory on the PC, just insert the USB memory device into a USB port of the PC.

12.5 Store USB Memory Files in External Memory User Box

Preparation required to use this function (for the administrator)

Enable to read files from a USB memory.

Reading files from a USB memory is prohibited by default.

For details on how to configure the system settings for USB memory operation, refer to "User's Guide[Descriptions of Functions/Utility Keys]/[Utility]".



Related setting (for the administrator)

- If User Authentication has been implemented, you can set permissions for every registration user and public users to read files from USB Memory (Default: [Restrict]). For details, refer to "User's Guide[Descriptions of Functions/Utility Keys]/[Utility]".
- If you are logging in as a User Box administrator with user authentication implemented, you cannot save files in a USB memory device in a User Box.

Operation flow

Any of PDF, Compact PDF, JPEG, TIFF, XPS, Compact XPS, OOXML (.docx/.xlsx/.pptx), and PPML (.ppml/.vdx/.zip) format files can be read.



Tips

- You can also store encrypted PDF, searchable PDF, and outline PDF files in USB memory device.

- 1 Insert a USB memory device into the USB port of the machine.

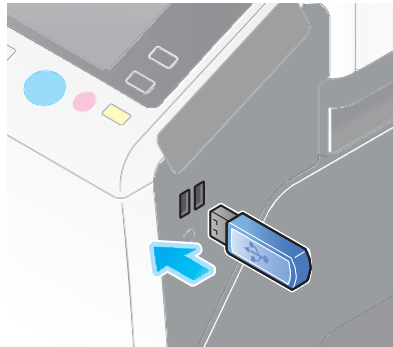

NOTICE

When this machine is starting up, do not insert or remove the USB memory device to/from the USB port.

- 2 Tap [Save Ext. Memory Doc. in User Box].
 - You can also print files by selecting the User Box mode and by tapping [System] - [External Memory].

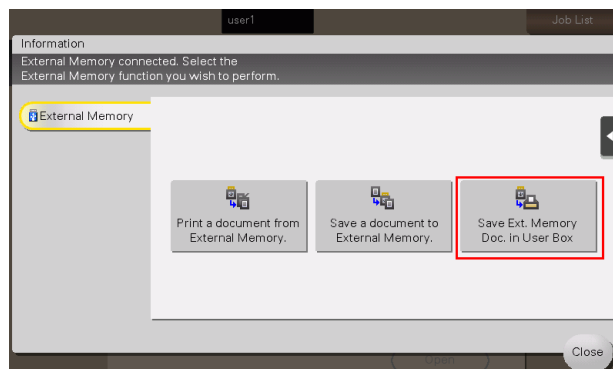

- 3 Select a file, then tap [Other] - [Save in User Box].
 - In the [File Path] column, you can directly enter a path to the folder, which contains a file you wish to store in the User Box.
 - Tap [Top] to move upward.
 - Tap [Open] to open the folder and move downward.
 - Tap [Details] to display and check the detailed file information.

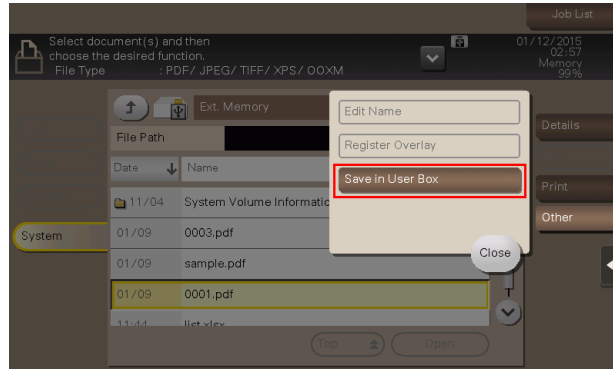

- 4 Select a User Box in which to save a file, then tap [OK].
 - Tap [Search], and you can search for a User Box. Tap [New], and you can create a new User Box. For details, refer to "User's Guide[Descriptions of Functions/Utility Keys]/[User Box]".
- 5 Rename the file if necessary.
 - If you have selected multiple files, you cannot rename them.

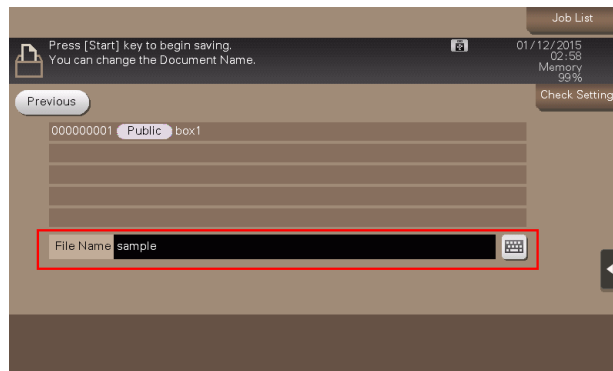

- 6 Press the **Start** key.
The file is stored in the External Memory User Box.



- 7 When the operation is complete, remove the USB memory device from the port of this machine.

⦿ Reference

When you save a password protected PDF file, the file is stored in the Password Encrypted PDF User Box. To store a file from the Password Encrypted PDF User Box to a User Box you select, refer to page 7-3.

13

Appendix

13 Appendix

13.1 Optional Settings before File Storage

Changing a file name ([File Name])

You can rename a file of the scanned original if necessary (using up to 30 characters).

When you do not change the file name, the file name is automatically assigned according to the rule of "Initial of the function" + "Device Name" + "Date" + "sequential number" + "Page Number" + "File extension". A file name consists of the following information:

Item	Description
Initial of the function	Indicates the mode used for scanning data. <ul style="list-style-type: none"> • C: Copy • S: Scan/Fax or User Box • P: Print • R: Received fax
Device Name	The name of this machine registered in [Utility] - [Administrator Settings] - [Administrator/Machine Setting] - [Input Machine Address] - [Device Name].
Date	Indicates the date and time when the original was scanned. For example "11050115230" means that the file was scanned on May 1, 2011, 15:23. The last digit (0) indicates the order when file conversion is performed multiple times in a certain minute. If file conversion is performed twice between 15:23 and 24, the last digit appears as 231 and 232.
Sequential number	A sequential number is given when a multi-page original is converted by page, and the number indicates the page number of original data. Page numbers are automatically included in the file name when the file is saved or sent. Consider this part for FTP Send or other transmission when a FTP server has restrictions regarding file names.
File extension	Extension of the file to be saved. An extension is automatically included in the file name when the file is saved or sent.

Related setting (for the administrator)

- You can change the default file name. You can specify whether to add an initial of the function or whether to specify an arbitrary text instead of the device name. For details, refer to "User's Guide[Descriptions of Functions/Utility Keys]/[Utility]".

Scanning a 2-sided original ([Simplex/Duplex])

Using the **ADF**, you can automatically scan the front and back sides of an original. Also, you can scan only one side of the first page, then scan both sides of the remaining pages.

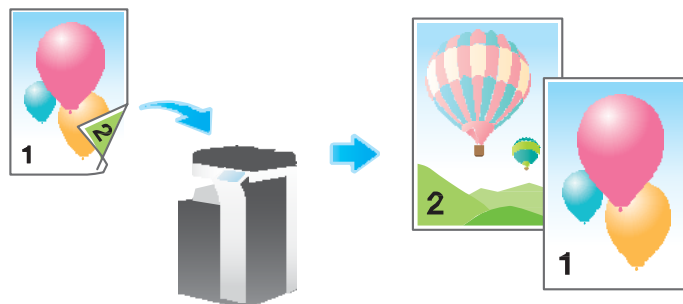

Settings	Description
[1-Sided]	Scans a single side of original.
[2-Sided]	Scans both sides of the original.
[Cover + 2-sided]	Scans a single side of the first page, and scans both sides of the remaining pages.

Specifying the resolution to scan the original ([Resolution])

Select a resolution to use to scan the original.

Settings	Description
[Scan Resolution]	<p>Select a resolution of the original to be saved in the User Box.</p> <ul style="list-style-type: none"> [200 x 200 dpi]: Select this option to scan a standard original. [300 x 300 dpi]: Select this option to scan a standard original with a higher resolution. [400 x 400 dpi]: Select this option to scan an original containing small characters and drawings. [600 x 600 dpi]: Select this option to convert an original into a file of the maximum size. Select this option to scan an original such as a full color photo with a fine image quality level.
[Fax Resolution]	<p>Select a resolution to use to scan the original for fax transmission. To use Fax TX, Internet Fax, or IP Address Fax, scan the original in the following resolution.</p> <ul style="list-style-type: none"> [Normal]: Select this option to scan originals that do not require a fine level of image quality, or when you want to send a large number of originals quickly. [Fine]: Select this option to scan a standard original. [Super Fine]: Select this option to scan originals containing small characters or drawings. [Ultra Fine]: Select this option to scan originals that require a fine level of image quality.

Selecting the color mode to scan the original ([Color])

Select a color mode for scanning originals.

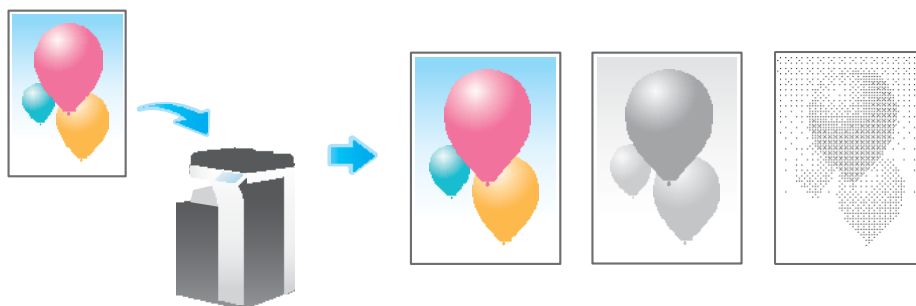

Settings	Description
[Auto Color]	Scan by automatically selecting either [Full Color] or [Gray Scale] according to the original color.
[Full Color]	Scan in full color, regardless of whether the original is in color or in black and white. Select this option to scan an original that has colors other than black and white or scan a color photo.
[Gray Scale]	Scans in gray scale, regardless of whether the original is in color or black and white. Use this option to scan the original having many halftone images such as black and white photos.

Settings	Description
[Black]	Scans the original in black or white without using neutral colors between black and white. Use this option to scan an original that has clear boundaries between black and white (for example, a line drawing).

Specifying the file type used to save the scanned original data ([File Type])

The available file types are PDF, TIFF, JPEG, XPS, PPTX, DOCX, XLSX, and other types. You should use the password encrypted PDF file format to store important original data.

Settings	Description
[File Type]	Select the file type to be saved from the following: <ul style="list-style-type: none"> [PDF]: A type available in most operating systems, which allows you to assign a password to a file or encrypt a file. Important original data should be saved as a PDF file. [Compact PDF]: Save to a file that has a smaller size than normal PDF format. We recommend this format when you want to reduce file size to enable sending by E-mail etc. [TIFF]: This is one kind of versatile image formats. TIFF format supports multiple pages, in which multi-page documents can be saved as single file. [JPEG]: A file format widely used in digital cameras. Suitable for saving photo data. JPEG format does not support the saving of multiple pages as a single file. [XPS]: A new image file format introduced in Windows Vista. [Compact XPS]: Save to a file that has a smaller size than normal XPS format. [PPTX]: Extension of an XML-base file that is created with PowerPoint of Microsoft Office 2007 or later. [DOCX]: Extension of an XML-base file that is created using Word of Microsoft Office 2007 or later. [XLSX]: Extension of an XML-base file that is created using Excel of Microsoft Office 2007 or later.
[Page Setting]	Tap this button to select a filing page unit when an original consists of multiple pages. <ul style="list-style-type: none"> [Multi Page]: Select this check box to convert all pages to a single file. However, if [File Type] is set to [JPEG], you cannot select [Multi Page]. [Page Separation]: Select this option to divide a file into a specified number of pages for transmission using E-mail, SMB, or FTP transmission. For example, if you enter "2" to scan 10 original pages, the original is divided into five separate files. The specified number of pages is stored and the pages are saved as a single file ([Multi Page]) when saved.
[E-mail Attachment Method]	You can select the E-mail attachment method when [Page Setting] is set to [Page Separation]. <ul style="list-style-type: none"> [All Files Sent as 1 E-mail]: Attach all files to one E-mail. [1 File per E-Mail]: Attach one file to one E-mail.
[PDF Detail Setting]	If [PDF] or [Compact PDF] is selected for the file format, you can configure the PDF option settings. You can enhance security by attaching a digital signature that identifies the author of the file, by file encryption, etc.

[PDF Detail Setting] allows the following settings.

Settings	Description
[Encryption]	<p>Select [ON] to encrypt a file.</p> <ul style="list-style-type: none"> [Password]: Enter the password to restrict access to the file. Create a PDF file that is accessible by specific users who know the password. [Permissions Password]: To specify permissions for printing and editing a PDF file, enter an authorization password. [Encryption Level]: When specifying permissions for a PDF file, select an encryption level according to the security level that you want to specify. If you select [High Level], you can specify permissions in more detail. [Printing Allowed]: Select whether to allow users to print PDF files. If [Encryption Level] is set to [High Level], you can permit printing of PDF files only in low resolution ([Low Resolution]). [Copy Contents]: Select whether to allow users to copy text and image from PDF files. [Changes Allowed]: Select the content of PDF for which modification is permitted. If [Encryption Level] is set to [High Level], you can select the contents to be permitted in more detail.
[Digital Signature]	<p>Select [ON] to add a digital signature (certificate) of this machine to a PDF file, and select [SHA1] or [SHA256] as the encryption level of the signature. You can certify the author of a PDF, and prevent forgery or unauthorized modification. This function is enabled when a certification is registered on this machine.</p>
[Outline PDF]	<p>Specify this option to save a file in compact PDF format. The text is extracted from the original and converted into a vector image.</p>

Tips

- The optional **Extension Memory** and **i-Option LK-110 v2** are required to specify DOCX or XLSX for the file type.
- The file types XPS, Compact XPS, and PPTX are available when the Web browser function is disabled. When the optional **Extension Memory** is installed, they are available regardless of whether the Web browser function is enabled or disabled.

Specifying the original size for scanning ([Scan Size])

Select the size of the original to be scanned.

Settings	Description
[Auto]	Selects a scan size automatically according to the original, and scans the original.
[Inches]	Select this option to scan an inch-size original. Tap [Inches], and select a standard inch size.
[Metric Sizes]	Select this option to scan a metric-size original. Tap [Metric Sizes], and select the standard metric size respectively.
[Other]	Select this option to scan a postcard (4 x 6, or A6 Card) or an original other than an inch- or metric- size original. Tapping [Other] allows you to select each standard size.
[Photo Size]	Select this option to scan photos or originals in photo size. Tap [Photo Size], and select a standard size.
[Custom Size]	Select this option to scan originals in custom size. Enter vertical and horizontal values.

Scanning originals of varying sizes in a batch ([Mixed Original])

Even for an original with pages of different sizes, by using the **ADF**, you can scan data while detecting the size of each page. If the widths of the originals are the same, select [Same Width]. If the widths of the originals are different, select [Different Width].

NOTICE

*Load all the original pages into the **ADF** so that the top edges of the pages are toward the back or the left side of the machine.*



Scanning an original thinner than normal paper ([Thin Paper Original])

Reduce the original feed speed of the **ADF** to prevent thin paper from getting caught.

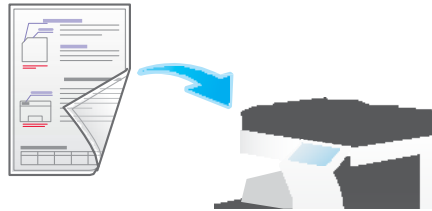

Scanning a folded original ([Z-Folded Original])

Even the original sizes of folded originals can be detected accurately.

If a folded original is loaded into the **ADF**, its size may not be detected correctly. To scan a folded original through the **ADF**, use [Z-Folded Original].

NOTICE

*Unfold folded originals before loading them into the **ADF**. If a folded original is not unfolded before scanning, a paper jam may occur or the size may not be correctly detected.*

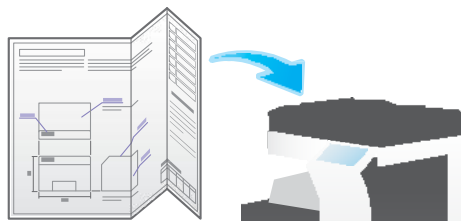

Scanning a long original ([Long Original])

Load the long original on the **ADF** if it cannot be placed on the **Original Glass** and is larger in the feeding direction than the full standard size (11 x 17 or A3). There is no need of entering the original size in advance but **ADF** will detect the size automatically.

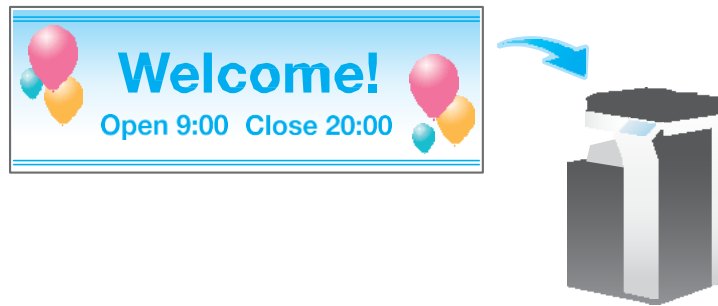

Tips

- This function is available when the Web browser function is disabled. When the optional **Extension Memory** is installed, this function is available regardless of whether the Web browser function is enabled or disabled.

Specifying the original loading direction ([Original Direction])

When scanning a double-sided original, you can specify the original loading direction so that the vertical direction is set correctly after scanning.

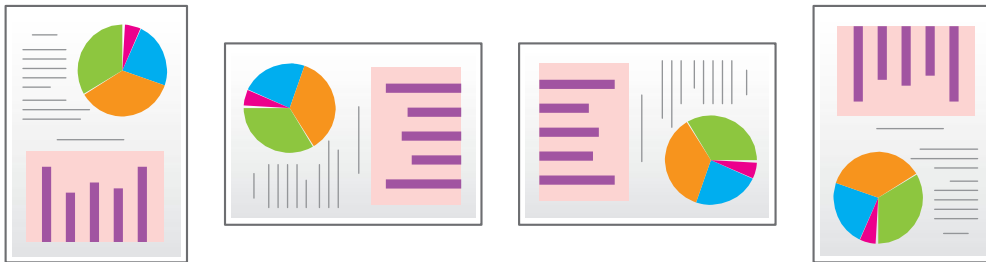

Specifying the original binding position ([Binding Position])

When scanning a double-sided original, specify the binding position of the original in [Binding Position] to prevent the binding position from being reversed between the front and rear faces.



Settings	Description
[Auto]	Automatically configures the binding position of the original. When the long side of the original is 11-11/16 inches (297 mm) or less, the binding position is set to the long side of the paper. When the long side of the original exceeds 11-11/16 inches (297 mm), the binding position is set to the short side of the paper.
[Left Bind]	Select this option when the binding position is set to the left of the original.
[Top Bind]	Select this option when the binding position is set to the top of the original.

Scanning while removing dust in the slit glass ([Despeckle])

When scanning an original through **ADF**, scanning of original and dust removal from the **Slit Scan Glass** are performed alternately, so that the original is always scanned using clean **Slit Scan Glass**.

It takes longer to finish scanning of originals, compared to the normal operation.

Skipping blank pages ([Blank Page Removal])

If blank pages are included in the original loaded into the **ADF**, they are skipped when the original is scanned.

Select this check box when scanning an original containing blank pages. Any blank pages that are detected are not counted as original pages.

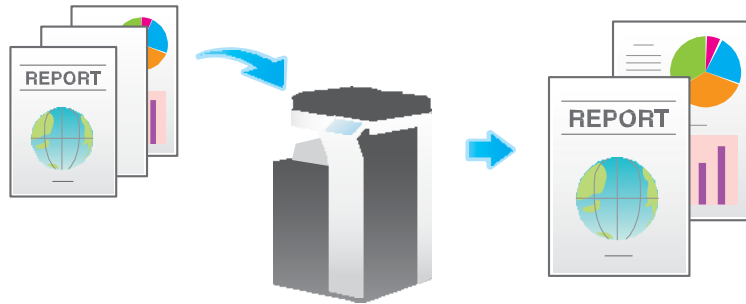

Splitting the left and right pages of a book and catalog ([Book Original])

You can scan two-page spreads such as books and catalogs separately into the left and right pages, or scan a page spread as a single page. If you place a book or catalog on the **Original Glass**, you do not need to close the **ADF** to scan it.



Settings	Description
[ON]/[OFF]	Select [ON] to specify Book Original.
[Output Method]	Specify the scanning method for book spread originals. <ul style="list-style-type: none"> • [Book Spread]: Scan a two-page spread as one page. • [Separation]: Scan the right and left pages of two-page spreads separately in page number order. • [Front Cover]: Scan the front cover and two-page spreads according to the page order of the original (scan in the order of front cover and two-page spreads). • [Front & Back Covers]: Scan the front and back covers and two-page spreads according to the page order of the original (scan in the order of front cover, back cover, and two-page spreads).
[Binding Position]	If [Separation], [Front Cover] or [Front & Back Covers] is selected for [Output Method], select the two-page spread binding position. Select [Left Bind] for two-page spreads of left binding, and [Right Bind] for two-page spreads of right binding. Note that if the binding position is incorrectly specified, the page order of the two-page spread is reversed between the left- and right-hand pages.

Settings	Description
[Frame Erase]	<p>Erases the shadow of the surrounding that is created when the original cover cannot be closed properly due to the thickness of the original. You can erase the four sides of the original to the same width. Additionally, you can erase the four sides of the original to different widths.</p> <ul style="list-style-type: none"> [Frame]: Select this option to erase the four sides of the original to the same width. In [Erase Amount], tap [+] / [-] for the inch area, tap [+] / [-] or Keypad for the centimeter area to specify the width of the area to be erased. To display the Keypad, tap the input area for the numeral. [Top]/[Bottom]/[Left]/[Right]: Select this option to erase the four sides of the original by specifying different widths for different sides. Clear the Frame check box, select a side ([Top], [Bottom], [Left] or [Right]) and specify the width of the area in [Erase Amount] by tapping [+] / [-] for an inch area and by tapping [+] / [-] or the Keypad for a centimeter area. To display the Keypad, tap the input area for the numeral. If you do not want to erase the side, cancel the setting for [Erase].
[Center Erase]	<p>Erases the shadow created in the center when the original cover cannot be closed correctly due to the thickness of the original. Specify the width of the area to erase by tapping [+] / [-] for the inch area and by tapping [+] / [-] or Keypad for the centimeter area. To display the Keypad, tap the input area for the numeral.</p>

Scanning a number of originals in several batches ([Separate Scan])

If the number of original sheets is so large that they cannot be loaded into the **ADF** at the same time, you can load them in several batches and handle them as one job.

In [Separate Scan], you can switch between the **ADF** and the **Original Glass** to scan the originals.

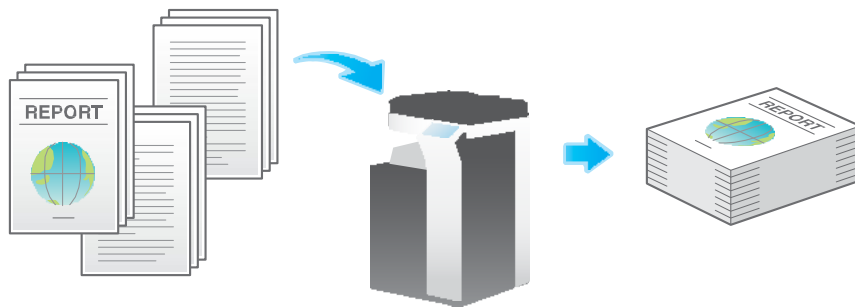

- 1 Load the original.

NOTICE

*Do not load more than 100 sheets at a time into the original tray, and do not load the sheets up to the point where the top of the stack is higher than the ▼ mark. Doing so may cause an original paper jam, damage the originals, and/or cause an **ADF** failure.*

- 2 Tap [Application] - [No. of Originals] - [Separate Scan], and set to [ON].

→ Set options if necessary.

- 3 Press the **Start** key.

The original is scanned.

- 4 Load the next original, then press the **Start** key.
 → If desired, tap [Change Setting] to change the option settings according to the new original.

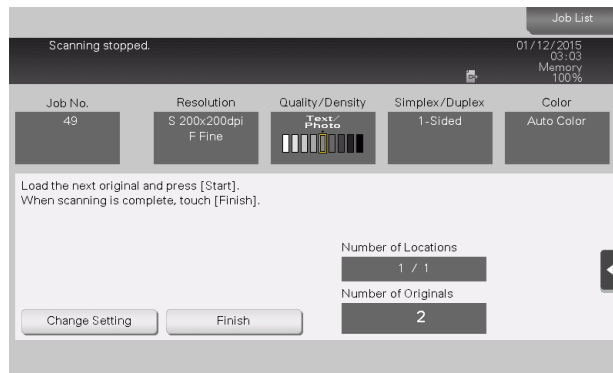

- 5 Repeat Step 4 until all pages of the original are scanned.
- 6 After all originals are scanned, tap [Finish] and press the **Start** key.

Selecting the appropriate image quality for the contents of the original ([Original Type])

Select the appropriate image quality level for the original and scan at the optimal level of image quality.



Settings	Description
[Text]	Tap this button to scan an original, which consists mostly of text, at the optimum level of image quality. This function sharpens the edges of each character, creating easy-to-read images.
[Text/Photo Printed]	Tap this button to scan an original consisting primarily of text and photos at the optimum image quality level. Sharpen the edges of text, and smoothen photos. Select this option to scan printed originals such as brochures and catalogs.
[Text/Photo PhotoPaper]	Tap this button to scan an original consisting primarily of text and photos at the optimum image quality level. Sharpen the edges of text, and smoothen photos. Select this option to scan originals in that include photos printed on photographic paper.
[Photo Printed]	Tap this button to scan an original consisting of only photos at the optimum image quality level. Select this option to scan printed originals such as brochures and catalogs.
[Photo PhotoPaper]	Tap this button to scan an original consisting of only photos at the optimum image quality level. Select this option for scanning originals printed on photographic paper.
[Dot Matrix Original]	Tap this button to scan an original, which consists mostly of text such as thin or faint characters, at the optimum level of image quality. This function reproduces text using high pixel density, creating easy-to-read text.
[Copied Paper]	Tap this button to scan an original with the even density, which is printed out by the copier or printer, with the optimum image quality.

Adjusting the density to scan the original ([Density])

Adjust the density (Dark or Light) to scan the original.

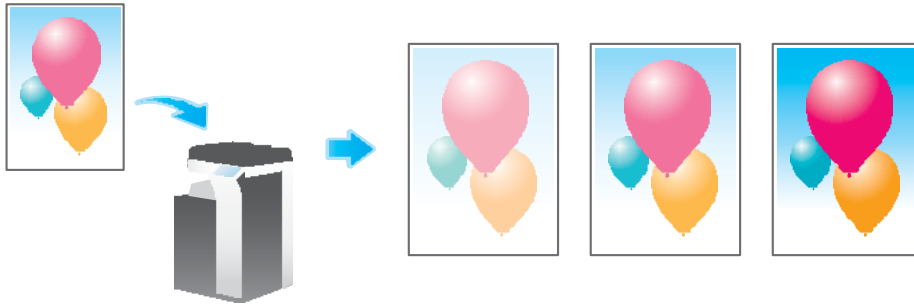

Adjusting the background density of the original to be scanned ([Bkgd. Removal])

You can adjust the density of the background area for originals with colored background (newspaper, recycled paper, etc.) or originals that are so thin that text or images on the back would be scanned.

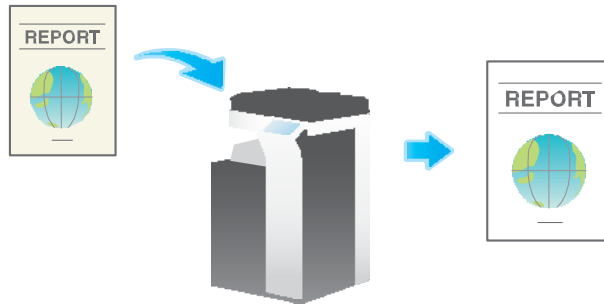

Settings	Description
[Background Removal]	Tap this button to scan a 2-sided original made of thin paper or an original with the colored background, with the optimum image quality. <ul style="list-style-type: none"> [Bleed Removal]: Select this option to prevent a back-side bleeding when printing a 2-sided original that is so thin that the contents of the back side would be scanned. [Paper Discoloration Adjustment]: Select this option to scan an original with a colored background such as a map.
[Background Removal Level]	Tap this button to adjust the density of the background color for an original with a colored background. Selecting [Auto] automatically determines the density of the background color, and scans an original at the optimum background density level.

Scanning after erasing text and shadows in the margins of an original ([Frame Erase])

Erase four sides of the original to the specified width. You can specify the width to be erased for each side.

This is convenient when you want to erase the reception record of the header and footer of a fax, or shadow of punch holes in the original.



Settings	Description
[ON]/[OFF]	Select [ON] to specify Frame Erase.
[Frame]	Select this option to erase the four sides of the original to the same width. In [Erase Amount], tap [+]/[-] for the inch area, tap [+]/[-] or Keypad for the centimeter area to specify the width of the area to be erased. To display the Keypad , tap the input area for the numeral.
[Top]/[Bottom]/[Left]/[Right]	Select this option to erase the four sides of the original to different widths. Clear the [Frame] check box, select a side ([Top], [Bottom], [Left] or [Right]) and specify the width of the area in [Erase Amount] by tapping [+]/[-] for an inch area and by tapping [+]/[-] or Keypad for a centimeter area. To display the Keypad , tap the input area for the numeral. If you do not want to erase the side, cancel the setting for [Erase].

Sharpen the boarder between text etc. ([Sharpness])

Sharpen the edges of images such as text in the table and graphics to improve legibility.

Smothen the rough contours of images or sharpen blurred images.

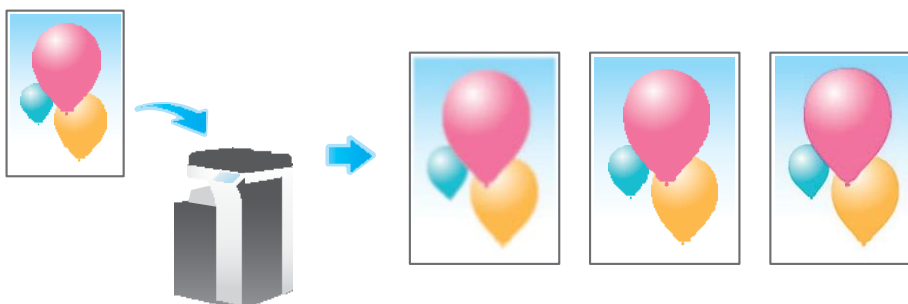

13.2 Optional Settings before Printing

Enlarge or reduce an image ([Zoom])

You can zoom a file image and print it to the desired scale.

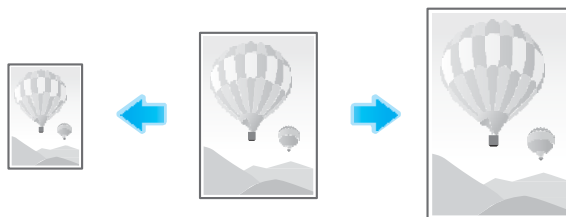

Settings	Description
[Settings when saving]	Print an original image in the zoom ratio you have set during image saving.
[+]/[-]	Enter a zoom ratio manually. You can also enter the zoom ratio from the Keypad . To display the Keypad , tap the input area for the numeral.
Fixed Zoom	Select a fixed zoom ratio to print on the standard-size paper.
[Minimal]	Slightly reduces the size of the original, places the original image at the center position, and prints it out. Use this option to print the entire original image including its edges.
[Zoom Ratio]	Prints the original in the preset scale.

Specifying paper ([Paper])

Select a paper size and type and print a file.

Settings	Description
[Auto]	Tap this button to automatically select optimum sized paper for the original before printing.
[1] - [4]	Specify paper for printing.
[#]	Tap this button to print onto the paper loaded into the Bypass Tray .

Printing on both sides of paper ([Simplex/Duplex])

Select to print on a single side or both sides of a sheet of paper.

If you print on both sides of paper, you can reduce paper usage by half. You can save more sheets by combination of the Combine function.

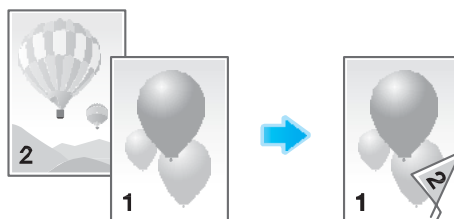

Settings	Description
[Simplex/Duplex]	The original is printed either on a single side or on both sides of paper.
[Continuous Print]* ¹	This can be set if the [Simplex/Duplex] is set to [2-Sided]. Select this check box to print the next file on the rear side of paper after you have printed out a file consisting of odd-numbered pages.
[Binding Position]* ²	This can be set if the [Simplex/Duplex] is set to [2-Sided]. Select the binding position.

*1[Continuous Print] is displayed when Combine is selected for the User Box.

*2[Binding Position] is displayed when data is printed from an external memory.

Printing multiple pages on the same side of a single sheet ([Combine])

You can save sheets by reducing and copying multiple pages (such as 2, 4 or 8 pages) on the same side of a single sheet.

If [4in1] or [8in1] is selected, you can set the combined page layout to [Horizontal] or [Vertical].

You can save more sheets by combination of the 2-Sided copy function.



Stapled sheets ([Staple])

Each set of sheets can be stapled (at a corner or at two positions) and output automatically. This function is useful for preparing a project proposal or other booklet materials.

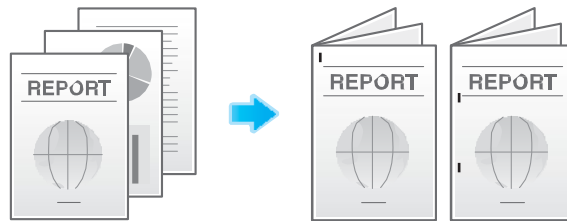

Settings	Description
[Corner]	Each set of printed sheets is stapled in a corner (top left or top right) before it is output.
[2 Position]	Each set of printed sheets is stapled at two positions (in the top, left, or right) before it is output.
[Position Setting]	Select the binding position. If [Auto] is specified for the binding position, the binding position is determined automatically based on the direction of print file.

Tips

- To use the Staple function, the optional **Finisher** is required.

Punching the printed sheets ([Punch])

Printed sheets are punched for filing and output. This function is useful when you want to bind printed materials in files.

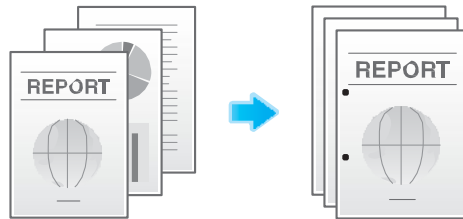

Settings	Description
[Position Setting]	Select a position to punch. If the punch position is set to [Auto], the position to punch is determined automatically based on the direction of print file.

Tips

- To use the Punch function, the **Finisher FS-534** and **Punch Kit PK-520** or the **Finisher FS-533** and **Punch Kit PK-519** are required.
- The number of punched holes varies depending on the country you are in.

Folding/Biding ([Fold/Bind])

Printed sheets can be folded or bound and output automatically.

Half-Fold

Feeds out a printed sheet by folding it in two. Also select the unit by which the paper is folded from [By Copy Job (Multiple Sheets)], [1 Unit], and [By Page]. When you set [By Page], specify the number of pages to be folded at one time.

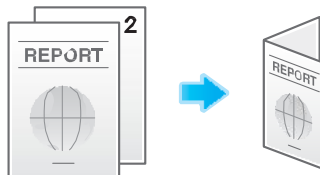

Tri-Fold

Feeds out a printed sheet by folding it in three. Also select the unit by which the paper is folded from [By Copy Job (Multiple Sheets)], [1 Unit], and [By Page]. When you set [By Page], specify the number of pages to be folded at one time.



Center Staple

Staples and feeds out a printed sheet by folding it in two.

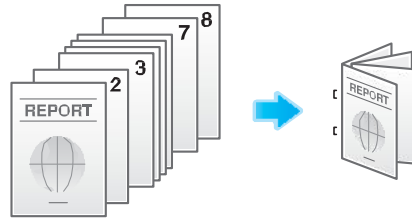

Tips

- To use the Half-Fold/Center Staple function, the **Finisher FS-534** and **Saddle Stitcher SD-511** are required.
- To use the Tri-Fold function, the **Finisher FS-534** and **Saddle Stitcher SD-511** are required.
- The Tri-Fold function is available when data is printed from the User Box, Secure Print User Box, Annotation User Box, or external memory.

Outputting by sets ([Group/Sort])

Select whether to sort the output sheets or group them when printing multiple sets of copies.

When you use both the Sort and Offset functions, the output position of each set is staggered to enable you to easily prepare handouts.

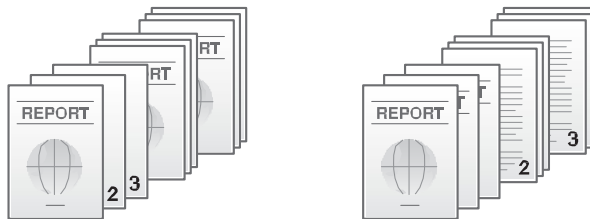

Settings	Description
[Group]	Select this item to feed out separately page by page such as "111", "222", "333", "444", and "555".
[Sort]	Select this item to feed out copies separately one by one such as "12345", "12345", and "12345".

Outputting each set in staggered position ([Offset])

When printing multiple sets of paper, you can offset the paper output position for easy separation.

If the **Finisher** or **Job Separator JS-506** is installed, the printed sheets are fed out and stacked on top of each other with each copy or page set staggered to separate them.

If the **Finisher** or **Job Separator JS-506** is not installed, the printed sheets are fed out and sorted by copies or page in an alternating crisscross pattern when the following conditions are satisfied.

- 8-1/2 x 11, A4, or B5 paper is used
- Paper of the same size and type is loaded with the w orientation in one paper tray and with the v orientation in another tray
- Specifying Auto Paper for the paper size setting

You can offset the paper output position by using the Sort and Offset functions. This function is useful to prepare handouts.



Printing a sheet or book ([Sheet/Book Print])

Select whether to print the currently selected sheet or the entire book when printing an OOXML format (.xlsx) file.

Settings	Description
[All Sheets]	Prints all sheets of the book.
[Current Sheet]	Prints the currently selected sheet only.

Tips

- [Sheet/Book Print] is available when data is printed from external memory.

Printing multiple pages in a PDF file, XPS file, or OOXML format file on the same side of a single sheet ([Combination])

You can combine multiple pages in a PDF file, XPS file, or OOXML format file into a single page for printing to reduce paper consumption.

Settings	Description
[ON]/[OFF]	Select [ON] to combine pages.
[No. of Page Combinations]	Specify the number of lines and columns (using up to 5 lines e 5 columns) of the original images to be placed on a single page.
[Combination Method]	Select the page layout of either [Horizontal] or [Vertical] layout.
[Combination Direction]	Set the layout of original images to be placed.
[Layout Settings]	Set a space between images, a zoom ratio of images, and page margin. <ul style="list-style-type: none"> • [Print Page Border]: Select this check box to add a frame around the page.

Tips

- [Combination] is available when data is printed from external memory.

Printing in a booklet format ([Booklet])

The pages in the original data are arranged and spread out in booklet format and printed on both sides of sheets. You can also specify the binding position, or insert front and back covers.

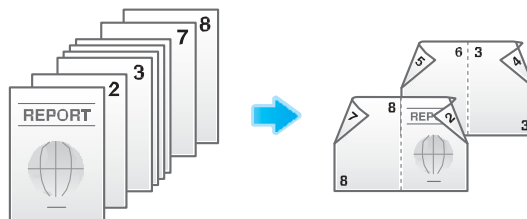

Settings	Description
[ON]/[OFF]	Select [ON] to specify Booklet.
[Left Bind]/[Right Bind]	Select the binding position of the printed sheets.
[Fold/Bind]	Staples printed sheets in the center or fold them in the center before discharging. <ul style="list-style-type: none"> • [Half-Fold]: Feeds out a printed sheet by folding it in two. • [Center Staple & Fold]: Staples and feeds out a printed sheet by folding it in two.
[Cover Sheet]	Specify this option to insert a different sheet of paper from text pages as the front cover of a booklet. <ul style="list-style-type: none"> • [Front(Copy)]: Prints the front page on the front sheet. • [Front(Blank)]: Inserts a blank front sheet. • [Paper]: Select the paper used for cover sheet.

Tips

- To use the Half-Fold/Center Staple function, the **Finisher FS-534** and **Saddle Stitcher SD-511** are required.

Adding margin on pages ([Page Margin])

You can add a binding margin to each page. Set a binding position and a margin for each page.

If an image is displaced due to an excessive margin, you can shift the image in horizontal or vertical direction and return to its original position. This is useful to adjust the image position when you file print sheets.



Settings	Description
[ON]/[OFF]	Select [ON] to set a page margin.
[Margin Position]	Select the paper binding position. <ul style="list-style-type: none"> • [Auto]: The binding direction is automatically set. When the long side of the file is 11-11/16 inches (297 mm) or less, the binding position is set to the long side of paper. When the long side of the file exceeds 11-11/16 inches (297 mm), the binding position is set to the short side of paper. • [Left Bind]: Select this option when setting the binding position to the left of paper. • [Right Bind]: Select this option when setting the binding position to the right of paper. • [Top Bind]: Select this option when setting the binding position to the top of paper.
[Margin Adjustment Value]	Adjust page the margin in the range 1/16 inch to 3/4 inch (0.1 mm to 20.0 mm). Adjust it by tapping [+]/[-] for the inch area, by tapping [+]/[-] or Keypad for the centimeter area. To display the Keypad , tap the input area for the numeral.

Tips

- If the positions of the staples or punched holes are different from the binding position, the positions of the staples or punched holes are given priority.
- If an image is partially lost due to incorrect margin setting, reduce the image size to print.

Fine-tuning the print position ([Image Shift])

You can fine tune the print position of the image upward, downward, rightward, and leftward with respect to the paper. Use this function when you want to make a fine adjustment, such as changing the print position a little or printing images in different positions between the front and back sides.

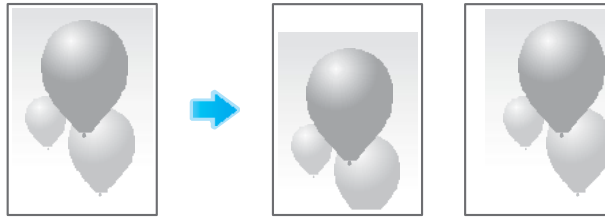

Settings	Description
[ON]/[OFF]	Select [ON] to shift an image.
[Front Side]/[Back Side]	Adjust the image position on the print paper by shifting it in horizontal or vertical direction. <ul style="list-style-type: none"> [Shift Left]/[Shift Right]: Shifts the image to the left or right. Adjust the shift amount by tapping [+]/[-] for the inch area, by tapping [+]/[-] or Keypad for the centimeter area. To display the Keypad, tap the input area for the numeral. [Shift Top]/[Shift Bottom]: Shift the image upward or downward. Adjust the shift amount by tapping [+]/[-] for the inch area, by tapping [+]/[-] or Keypad for the centimeter area. To display the Keypad, tap the input area for the numeral.
[Apply on Back]	Set this item to use the same settings as used on the front side for the rear side of the print paper.

Inserting front and back covers ([Cover Sheet])

You can insert cover sheets, which may be different from those used for the body, before the first page and after the end page of the original.

The front and rear cover sheets can be different from that of the text pages (in paper color and thickness). You can print them at the same time.



Settings	Description
[ON]/[OFF]	Select [ON] to specify Cover Sheet.
[Front Cover]	Inserts a front cover. <ul style="list-style-type: none"> [Front(Copy)]: Prints the front page on the front sheet. [Front(Blank)]: Inserts a blank front sheet. [Paper]: Select the paper used for cover sheet. Use the same size cover and body sheets, and stack them in the same orientation.
[Back Cover]	Inserts a back cover. <ul style="list-style-type: none"> [Back (Copy)]: Prints the last page on the back sheet. [Back(Blank)]: Inserts a blank back sheet. [Paper]: Select the paper used for back sheet. Use the same size cover and body sheets, and stack them in the same orientation.

Tips

- Use the same size cover and body sheets, and stack them in the same orientation.

Inserting a different sheet into the specified page ([Insert Sheet])

You can insert a different sheet from other pages into a specified page.

You can insert a color paper and a thick paper. Also, you can print or not print the original data on the inserted sheet.

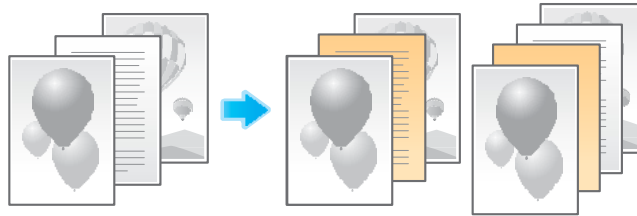

Settings	Description
[ON]/[OFF]	Select [ON] to specify Insert Sheet.
[Insert Position]	Set a page number where you wish to insert a different sheet. <ul style="list-style-type: none"> • Enter an insertion page number using the Keypad and tap [Add.] to register the insertion page number. To display the Keypad, tap the input area for the numeral. • If you have entered an incorrect page number, select this number and tap [Delete]. • If page numbers are entered in random sequence, they are rearranged in ascending order automatically.
[Insert Paper]	Select the paper tray loaded with the paper to be inserted. Use the same size of paper for the insert pages and text pages, and set them in the same direction.
[Insert Type]	Specify to print a file on the insertion papers or not.

Tips

- You can specify up to 30 positions for insert sheets.
- Use insert sheets and text sheets of the same size, and stack them in the same orientation.

Arrange the first page of the chapter on the front side ([Chapters])

During 2-Side printing, the first page of each chapter is always printed on the front side of the sheet of paper used.

The first page of each chapter and the text pages are printed on the same sheets. Also, you can use a sheet different from text sheets for the first page of each chapter.

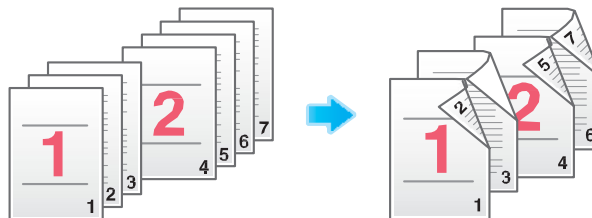

Settings	Description
[ON]/[OFF]	Tap [ON] to set the Chapters option.

Settings	Description
[Chapter Position]	Specify the chapter page to be printed on the front side. <ul style="list-style-type: none"> Enter the chapter location page number using the Keypad and tap [Add..] to register the page number. To display the Keypad, tap the input area for the numeral. If you have entered an incorrect chapter page number, select this number then tap [Delete]. If page numbers are entered in random sequence, they are rearranged in ascending order automatically.
[Insert Chapter]	Select whether to use the same page or a different page for the chapter and the text. <ul style="list-style-type: none"> [OFF]: Print all pages on the same paper. [Copy Insert]: Prints chapter pages on different sheets from text pages. Select the paper tray loaded with paper to be inserted in [Chapter Paper].
[Chapter Paper]	If [Insert Chapter] is set to [Copy Insert], select the paper tray containing the chapter paper. If the type of paper used for chapter papers and text papers differs, use the same size paper and stack them in the appropriate direction.

Tips

- You can set up to 30 positions for the first page of chapters.
- Make sure that the paper loaded for the first page of the chapter and for text copies are of the same size and orientation.
- When you set the Chapters function, the [Duplex/Combine] option is set to [2-Sided] automatically.

Adding the date and time ([Date/Time])

You can print the current date and time by selecting a print position and format.

The date and time can be printed either on all pages or only on the first page.

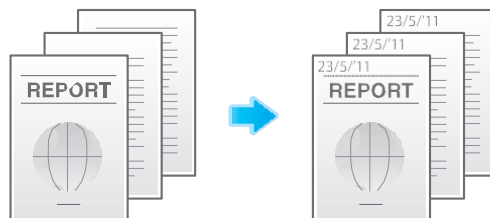

Settings	Description
[ON]/[OFF]	Select [ON] to print the date/time.
[Date Format]	Select the date/time format.
[Time Format]	Select the time format. If you do not want to print time, select [OFF].
[Pages]	Select the range of pages to print.
[Text Details]	If necessary, select the print size and font. <ul style="list-style-type: none"> Data is printed in black and white in this machine.
[Print Position]	If necessary, select the print position of the text. You can more finely adjust the print position in [Adjust Position].

Tips

- This function is available when the Web browser function is disabled. When the optional **Extension Memory** is installed, this function is available regardless of whether the Web browser function is enabled or disabled.

Adding the page number ([Page Number])

You can print page and chapter numbers by selecting a print position and format.

Page and chapter numbers are printed on all pages.

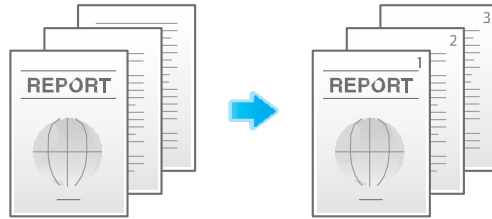

Settings	Description
[ON]/[OFF]	Select [ON] to print page numbers.
[Page Number Type]	Select the format of the page number.
[Starting Page Number]	Enter the starting page number to be printed on the first page using Keypad . To display the Keypad , tap the input area for the numeral. For example, to print page numbers from the third page of the file, enter "-1". The first page of the file is counted as "-1", the second page as "0", and the third page is counted as "1". In [Starting Page Number], a page number is printed on pages 1 and later. If "2" is entered, page numbers are printed from the first page of the file as "2, 3", etc. in order. "-" (minus sign) changes to + each time you tap [*].
[Starting Chapter Number]	Enter the starting chapter number if an original is divided into chapters, and you want to print chapter numbers from the second chapter using Keypad . To display the Keypad , tap the input area for the numeral. You can specify chapter numbers only when you have selected [Chapter Page] in [Page Number Type]. For example, to print chapter numbers from the third chapter, enter "-1". The first chapter of the file is counted as "-1", and the second chapter as "0", and the third chapter is counted as "1". In [Starting Chapter Number], chapter number is printed on the chapters that are count as 1 and later. If "2" is entered, number is printed from the first page of the first chapter of the file as "2-1, 2-2". "-" (minus sign) changes to + each time you tap [*].
[Text Details]	If necessary, select the print size and font. <ul style="list-style-type: none"> Data is printed in black and white in this machine.
[Print Position]	If necessary, select the print position of the text. You can more finely adjust the print position in [Adjust Position].
[Insert Sheet Setting] *	When you insert sheets using the Cover Sheet function of Insert Sheet function, specify whether or not to print a page number on the inserted sheet. <ul style="list-style-type: none"> [Cover Sheet]: Prints - or does not print - a page number on the cover sheet. The number of pages are counted even if [Do not print] is selected. [Insert Sheet (Copy)]: Prints a page number on the inserted paper or not. The number of inserted pages are counted even if [Do Not Print Number] is selected. If [Skip] is set, the page number is not printed and the number of pages is not counted. [Insert (Blank)]: Counts - or does not count - the inserted blank pages. The number of inserted pages is counted if [Do Not Print Number] is selected. If the [Skip] is set, the number of pages is not counted.

*[Insert Sheet Setting] is displayed when data is printed from the following User Boxes.

User Box

Secure Document User Box

Annotation User Box

Tips

- This function is available when the Web browser function is disabled. When the optional **Extension Memory** is installed, this function is available regardless of whether the Web browser function is enabled or disabled.

Adding a stamp ([Stamp])

Text such as "PLEASE REPLY" and "DO NOT COPY" are printed on the first page or all pages. You can select the text to be added from the registered fix stamps and arbitrary registered stamps.

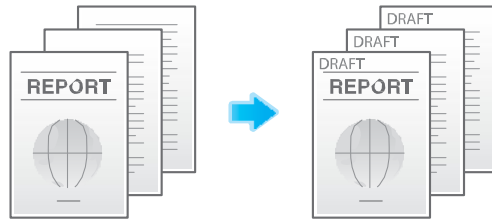

Settings	Description
[ON]/[OFF]	Select [ON] to print a stamp.
[Stamp Imprint]	Select the stamp you want to print.
[Pages]	Select the range of pages to print.
[Text Details]	If necessary, select the size of the text. <ul style="list-style-type: none"> Data is printed in black and white in this machine.
[Print Position]	If necessary, select the print position of the text. You can more finely adjust the print position in [Adjust Position].

Tips

- This function is available when the Web browser function is disabled. When the optional **Extension Memory** is installed, this function is available regardless of whether the Web browser function is enabled or disabled.

Adding the stamp on the entire page ([Stamp Repeat])

Stamp such as "Copy" and "Private" are printed on the entire page.

By printing text such as "Copy" or "Private" as a visible stamp, you can deter unauthorized copying.

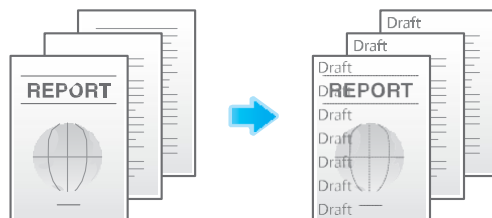

Settings	Description
[ON]/[OFF]	Select [ON] to repeatedly print a stamp.
[Stamp Repeat Type]	Select a stamp used. The date and time can also be printed. <ul style="list-style-type: none"> [Preset Stamp]: Select a preset stamp to be printed. [Registered Stamp]: Select a registered stamp to be printed. [Date/Time]: Select a format (type) of date and time to be printed. [Other]: Specify the job number, the machine's serial number, and distribution control number to be printed.
[Stamp Selection]	The registration status of the stamp is displayed.
[Detail Setting]	Select the density, size, and pattern overwriting of print characters if necessary. <ul style="list-style-type: none"> Data is printed in black and white in this machine.
[Change/Delete Position]	Allows to check, change or delete the stamp position settings if necessary. You can change the stamp sequence and insert a space between stamps. When you select up to four stamps, you can change their angle (within ^45 degrees).

Tips

- This function is available when the Web browser function is disabled. When the optional **Extension Memory** is installed, this function is available regardless of whether the Web browser function is enabled or disabled.

Adding information to the header/footer ([Header/Footer])

Add the date, time and any other desired text in the top and bottom margins (header/footer) of the specified page. You must register the information to be added for the header and footer in advance on this machine.

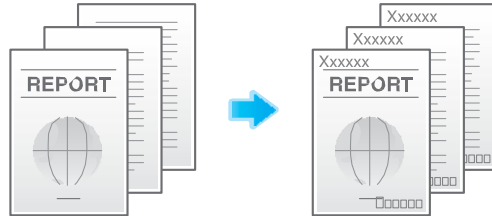

Settings	Description
[ON]/[OFF]	Select [ON] to print the header/footer.
[Recall Header/Footer]	Select the header/footer to be printed. Select the header/footer from among those registered in advance.
[Check/Change Temporarily]	If necessary, check or temporarily change the details of the program that is selected in [Recall Header/Footer]. <ul style="list-style-type: none"> • [Header Setting]: Change the content of the header. • [Footer Setting]: Change the content of the footer. • [Pages]: Change the range of pages to print. • [Text Details]: Change the print size and font. Data is printed in black and white in this machine.

Tips

- This function is available when the Web browser function is disabled. When the optional **Extension Memory** is installed, this function is available regardless of whether the Web browser function is enabled or disabled.

Composing stored images ([Registered Overlay])

You can recall registered overlay image and compose it to a file image. It will be useful to register frequently used overlay images.

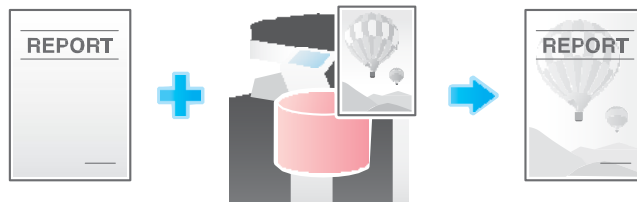

Settings	Description
[ON]/[OFF]	Select [ON] to overlay with a registered image.
[Recall Overlay Image]	Specify which side of the paper to compose the overlay image, and select an overlay image to be composed. Check the density, composition method, and preview of overlay image if necessary. If you set [Apply on Back], the image on the front side is composed on the back side of paper.
[Pages]	Select the range of pages on which an overlay image is composed.

Tips

- This function is available when this machine is equipped with an optional **Extension Memory**.

Printing a concealed security watermark ([Copy Protect])

Text such as "Copy" and "Private" are printed as concealed text. This function is called the Copy Protect function.

When a copy-protected document is copied, the concealed security watermark appears on the entire page, thereby indicating that it is an unauthorized copy.

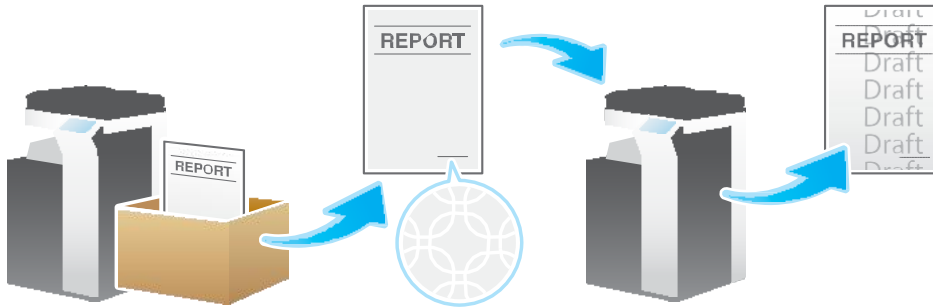

Settings	Description
[ON]/[OFF]	Select [ON] to print the copy protection text.
[Copy Protect Type]	Select a stamp used. The date and time can also be printed. <ul style="list-style-type: none"> • [Preset Stamp]: Select a preset stamp to be printed. • [Registered Stamp]: Select a registered stamp to be printed. • [Date/Time]: Select a format (type) of date and time to be printed. • [Other]: Specify the job number, the machine's serial number, and distribution control number to be printed.
[Stamp Selection]	The registration status of the stamp is displayed.
[Detail Setting]	Select the density, size, and pattern overwriting of print characters if necessary.
[Copy Protect]	Select how to print the copy protect pattern. Also, you can set the pattern contrast if necessary.
[Background Pattern]	Select a background pattern.
[Change/Delete Position]	Allows to check, change or delete the stamp position settings if necessary. You can change the stamp sequence and insert a space between stamps. When you select up to four stamps, you can change their angle (within ^45 degrees).

Tips

- This function is available when the Web browser function is disabled. When the optional **Extension Memory** is installed, this function is available regardless of whether the Web browser function is enabled or disabled.

13.3 Optional Settings before File Transfer

Change the file resolution ([Resolution])

You can change the resolution, used for file storage in the User Box, and transfer file at a different resolution.

Settings	Description
[Scan Resolution]	<p>Select the resolution to be used for scanning and sending of the original. To use E-mail TX, SMB TX, FTP TX, or WebDAV TX, the following resolution is selected for sending.</p> <ul style="list-style-type: none"> [Settings when saving]: Select this option to send the document in the same resolution as used for saving. [200 e 200 dpi]: Select this option to send the document in the standard resolution. [300 e 300 dpi]: Select this option to send the document in a higher resolution than the normal resolution. [400 e 400 dpi]: Select this option to send the document containing small characters and drawings. [600 e 600 dpi]: Select this option to convert the original to a file of the largest possible size. Use this option to scan a file such as a full color photo to have a fine image quality level.
[Fax Resolution]*	<p>Select the resolution of the original for sending a fax. To use Fax TX, Internet Fax, or IP Address Fax, send the original in the following resolution.</p> <ul style="list-style-type: none"> [Settings when saving]: Select this option to send the document in the same resolution as used for saving. [Normal]: Select this option to scan an original that does not require a fine image quality level, or to send a large number of originals in a short time. [Fine]: Select this option to send the document in the normal resolution. [Super Fine]: Select this option to send a file containing small characters or drawings. [Ultra Fine]: Select this option to send a file that requires a fine image quality level.

*[Fax Resolution] is displayed when a file is sent from a User Box.

Tips

- If the resolution is high, a large amount of information is scanned and the transmission time increases. When you use the E-mail TX or Internet Fax, make sure that the data capacity is not restricted.

Change the file color ([Color])

You can change the color mode settings, used for file storage in the User Box, and send the file in new color.

Settings	Description
[Use Existing Color Setting]	Sends a file in the same color mode as used during storage.
[Full Color]	Sends a file in full colors regardless of the mode selected for saving. Select this option to send color files and color photos.
[Gray Scale]	Sends a file in gray scale regardless of the mode selected for saving. Use this option to send an original that has many halftone images such as black and white photos.
[Black]	Sends the file in black or white without using neutral colors between black and white. Use this option to send an original that has clear boundaries between black and white (for example, a line drawing).

Change a file type ([File Type])

You can change the type of file, used for storage in the User Box, and transfer the file in new format.

The available file types are PDF, TIFF, JPEG, XPS, PPTX, DOCX, XLSX, Compact PDF, Compact XPS, and other types. You should use the password encrypted PDF file format to store important files.

Settings	Description
[File Type]	<p>Select a type of file you wish to send as follows.</p> <ul style="list-style-type: none"> [PDF]: A type available in most operating systems, which allows you to assign a password to a file or encrypt a file. Important original data should be saved as a PDF file. [Compact PDF]^{*1}: Used to send a file with a smaller file size than the normal PDF type. We recommend this format when you want to reduce file size to enable sending by E-mail etc. [TIFF]: This is one kind of versatile image formats. TIFF format supports multiple pages, in which multi-page documents can be saved as single file. [JPEG]^{*1}: A file format widely used in digital cameras. Suitable for saving photo data. JPEG format does not support the saving of multiple pages as a single file. [XPS]: A new image file format introduced in Windows Vista. [Compact XPS]^{*1}: Used to send a file with a smaller file size than the normal XPS type. [PPTX]^{*1}: Extension of an XML-base file that is created in PowerPoint of Microsoft Office 2007 or later. [DOCX]^{*1}: Extension of an XML-base file that is created using Word of Microsoft Office 2007 or later. [XLSX]^{*1}: Extension of an XML-base file that is created using Excel of Microsoft Office 2007 or later.
[Page Setting]	<p>Select a filing page unit when an original consists of multiple pages.</p> <ul style="list-style-type: none"> [Multi Page]: Select this check box to convert all pages to a single file. However, if [File Type] is set to [JPEG], you cannot select [Multi Page]. [Page Separation]^{*2}: Select this check box to divide a file into a specified number of pages for transmission using E-mail, SMB, or FTP transmission. For example, if you enter "2" to scan 10 original pages, they are separated into five files. <p>For E-mail, SMB, or FTP transmission of the files saved with Page Separation specified, [Page Separation] is enabled, and the number of pages specified at saving is applied. If necessary, the setting can be changed to [Multi Page].</p>
[E-mail Attachment Method] ^{*2}	<p>You can select the E-mail attachment method when [Page Setting] is set to [Page Separation].</p> <ul style="list-style-type: none"> [All Files Sent as 1 E-mail]: Attaches all files to one E-mail. [1 File per E-Mail]: Attach one file to one E-mail.
[PDF Detail Setting] ^{*3}	<p>If [PDF] or [Compact PDF] is selected for the file format, you can configure the PDF option settings.</p>

[PDF Detail Setting] allows the following settings.

Settings	Description
[Encryption]	<p>Select [ON] to encrypt a file.</p> <ul style="list-style-type: none"> [Password]: Enter the password to restrict access to the file. Create a PDF file that is accessible by specific users who know the password. [Permissions Password] : To specify permissions for printing and editing a PDF file, enter an authorization password. [Encryption Level]: When specifying permissions for a PDF file, select an encryption level according to the security level that you want to specify. If you select [High Level], you can specify permissions in more detail. [Printing Allowed]: Select whether to allow users to print PDF files. If [Encryption Level] is set to [High Level], you can permit printing of PDF files only in low resolution ([Low Resolution]). [Copy Contents]: Select whether to allow users to copy text and image from PDF files. [Changes Allowed]: Select the content of PDF for which modification is permitted. If [Encryption Level] is set to [High Level], you can select the contents to be permitted in more detail.

Settings	Description
[Digital Signature]	Select [ON] to add a digital signature (certificate) of this machine to a PDF file, and select [SHA1] or [SHA256] as the encryption level of the signature. You can certify the author of a PDF, and prevent forgery or unauthorized modification. This function is enabled when a certification is registered on this machine.
[Stamp Composition]	Specify this option to print date/time, page number, and header/footer on a PDF. Select [Text] if you want to embed the text to be printed on a PDF as text. If you select [Image], the text will be embedded as an image.
[Outline PDF]	Set this option to send file in compact PDF format. The text is extracted from the file and converted into a vector image.

*1[Compact PDF], [JPEG], [Compact XPS], [PPTX], [DOCX], or [XLSX] is displayed when a file is sent from a User Box or Annotation User Box.

*2[Page Separation] or [E-mail Attachment Method] is displayed when a file is sent from the User Box or Memory RX User Box.

*3 When a file is sent from the Memory RX User Box, only the following functions are available.

If the PDF processing function is enabled, you can configure [PDF Web Optimization] and [PDF/A]. For details on [PDF Web Optimization], refer to "User's Guide[Advanced Function Operations]/[Using the PDF Processing Function]". For details on [PDF/A], refer to "User's Guide[Advanced Function Operations]/[Using the PDF Processing Function]".

If the searchable PDF function is enabled, you can configure [Searchable PDF]. For details on the Searchable PDF function, refer to "User's Guide[Advanced Function Operations]/[Using the Searchable PDF Function]".

Tips

- The optional **Extension Memory** and **i-Option LK-110 v2** are required to specify DOCX or XLSX for the file type.
- The file types XPS, Compact XPS, and PPTX are available when the Web browser function is disabled. When the optional **Extension Memory** is installed, they are available regardless of whether the Web browser function is enabled or disabled.
- The optional **Extension Memory** and **i-Option LK-110 v2** are required to send data saved in a User Box from a computer in the compact PDF or compact XPS format.
- Even if the optional **Extension Memory** and **i-Option LK-110 v2** have not been installed, data saved in a User Box from this machine can be sent as long as it is in compact PDF or compact XPS format.

Changing a file or a subject ([File Name/Subject Name/Other])

You can rename a file to be transferred.

When sending an e-mail, correct its subject and text if necessary.

Settings	Description
[File Name]	You can change the file name that was set when saved in the User Box if necessary.
[Subject]	If necessary, change the subject of the E-mail. If fixed subject phrases are registered, you can select a subject from those registered.
[From]	If necessary, change the sender E-mail address. In normal circumstances, the E-mail address of the administrator is used as sender E-mail address. If user authentication is installed on this machine, the E-mail address of the login user is used as sender E-mail address.
[Body]	If necessary, change the message text of the E-mail. If fixed message text phrase is registered, you can select message text from those registered.

Adding the date and time ([Date/Time])

Set a stamp position and format, and add the file transmission date and time.
 The date and time can be printed either on all pages or only on the first page.

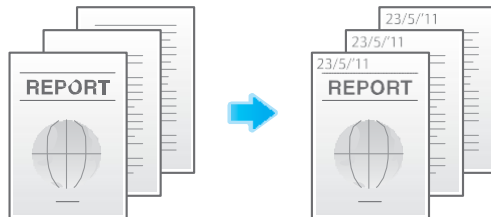

Settings	Description
[ON]/[OFF]	Select [ON] to print the date/time.
[Date Format]	Select the date/time format.
[Time Format]	Select the time format. If you do not want to print time, select [OFF].
[Pages]	Select the range of pages to print.
[Text Details]	If necessary, select the print size, font, and text color. <ul style="list-style-type: none"> Data is printed in black and white in this machine.
[Print Position]	If necessary, select the print position of the text. You can more finely adjust the print position in [Adjust Position].

Tips

- This function is available when the Web browser function is disabled. When the optional **Extension Memory** is installed, this function is available regardless of whether the Web browser function is enabled or disabled.

Adding the page number ([Page Number])

Select the stamping position and format, and add page and chapter numbers.
 Page and chapter numbers are printed on all pages.

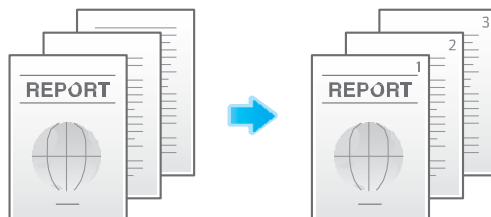

Settings	Description
[ON]/[OFF]	Select [ON] to print page numbers.
[Page Number Type]	Select the format of the page number.
[Starting Page Number]	Enter the starting page number to be printed on the first page using Keypad . To display the Keypad , tap the input area for the numeral. For example, to print page numbers from the third page of the file, enter "-1". The first page of the file is counted as "-1", the second page as "0", and the third page is counted as "1". In [Starting Page Number], a page number is printed on pages 1 and later. If "2" is entered, page numbers are printed from the first page of the file as "2, 3", etc. in order. "-" (minus sign) changes to + each time you tap [*].

Settings	Description
[Starting Chapter Number]	Enter the starting chapter number if an original is divided into chapters, and you want to print chapter numbers from the second chapter using Keypad . To display the Keypad , tap the input area for the numeral. You can specify chapter numbers only when you have selected [Chapter Page] in [Page Number Type]. For example, to print chapter numbers from the third chapter, enter "-1". The first chapter of the file is counted as "-1", and the second chapter as "0", and the third chapter is counted as "1". In [Starting Chapter Number], chapter number is printed on the chapters that are count as 1 and later. If "2" is entered, number is printed from the first page of the first chapter of the file as "2-1, 2-2". "-" (minus sign) changes to + each time you tap [*].
[Text Details]	If necessary, select the print size, font, and text color. <ul style="list-style-type: none"> Data is printed in black and white in this machine.
[Print Position]	If necessary, select the print position of the text. You can more finely adjust the print position in [Adjust Position].

Tips

- This function is available when the Web browser function is disabled. When the optional **Extension Memory** is installed, this function is available regardless of whether the Web browser function is enabled or disabled.

Adding a stamp ([Stamp])

Text such as "PLEASE REPLY" and "DO NOT COPY" are printed on the first page or all pages. You can select the text to be added from the registered fix stamps and arbitrary registered stamps.

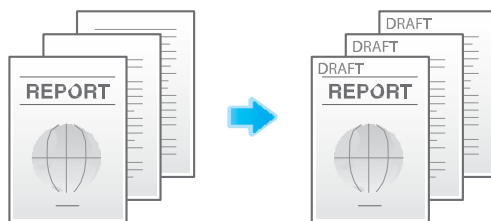

Settings	Description
[ON]/[OFF]	Select [ON] to print a stamp.
[Stamp Imprint]	Select the stamp you want to print.
[Pages]	Select the range of pages to print.
[Text Details]	If necessary, select the print size and text color. <ul style="list-style-type: none"> Data is printed in black and white in this machine.
[Print Position]	If necessary, select the print position of the text. You can more finely adjust the print position in [Adjust Position].

Tips

- This function is available when the Web browser function is disabled. When the optional **Extension Memory** is installed, this function is available regardless of whether the Web browser function is enabled or disabled.

Adding information to the header/footer ([Header/Footer])

Add the date, time and any other desired text in the top and bottom margins (header/footer) of the specified page. You must register the information to be added for the header and footer in advance on this machine.

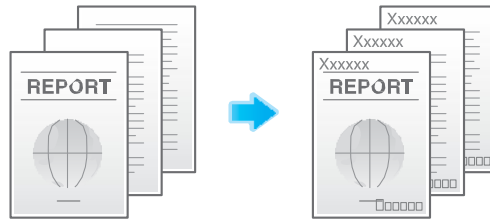

Settings	Description
[ON]/[OFF]	Select [ON] to print the header/footer.
[Recall Header/Footer]	Select the header/footer to be printed. Select the header/footer from among those registered in advance.
[Check/Change Temporarily]	<p>If necessary, check or temporarily change the details of the program that is selected in [Recall Header/Footer].</p> <ul style="list-style-type: none"> [Header Setting]: Change the content of the header. [Footer Setting]: Change the content of the footer. [Pages]: Change the range of pages to print. [Text Details]: Change the print size, font, and text color. <p>Data is printed in black and white in this machine.</p>

Tips

- This function is available when the Web browser function is disabled. When the optional **Extension Memory** is installed, this function is available regardless of whether the Web browser function is enabled or disabled.

Sending and printing at the same time ([Save & Print])

You can print data at the same time as you are using Scan or Fax TX.

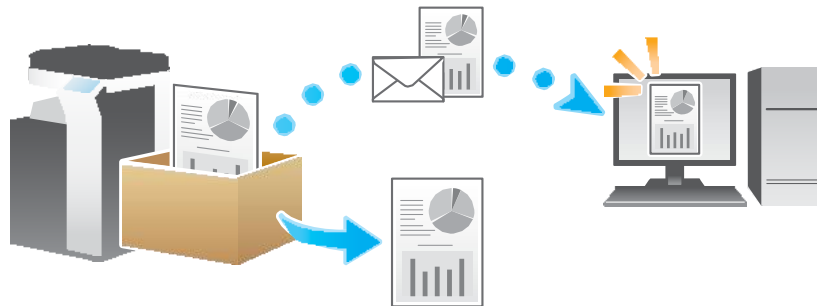

Settings	Description
[ON]/[OFF]	Select [ON] to send and print at the same time.
[No. of Sets]	If necessary, enter the number of copies to print.
[Simplex/Duplex]	Select [2-Sided] to print on both sides of sheets of paper.
[Staple]	<p>Select the binding positions for sheet stapling.</p> <ul style="list-style-type: none"> [Corner]: Each set of printed sheets is stapled in one corner before it is output. [2 Position]: Each set of printed sheets is stapled at two positions (in the top, left, or right) before it is output. [Position Setting]: Select the binding position. If [Auto] is specified for the binding position, the binding position is determined automatically.

Changing a character string to be printed ([Stamp Settings])

You can change the character string specified to register a User Box before sending data.

Settings	Description
[Date/Time]	Select a format for the date and time to be printed. Select the [Date/Time] box and tap the icon on the right side of the screen, then you can select a Date/Time format from the shortcut menu.
[Secondary Field]	Adds text to the number to be printed (using up to 20 characters).
[Density]	Select a density of the text to be printed.
[Number Type]	Select a number of digits of annotation to be printed. <ul style="list-style-type: none"> [Number Only]: Prints only the number of digits of the total file pages. [Put zeros in front]: Always prints an 8-digit number regardless of the number of file pages.
[Print Position]	Select a print position.

Report the destination of transfer file ([URL Dest. Settings])

When the SMB transmission, FTP transmission, or WebDAV transmission is complete, an e-mail showing the destination of transmission data is delivered to the specified address.

Encrypt an e-mail ([Mail Encryption])

You can encrypt e-mails to prevent wiretapping by third parties during transmission.

Add digital signature to e-mails ([Digital Signature])

When the MFP sends an e-mail, you can add a digital signature to it to prove the authenticity of the sender, and the recipient can confirm that data has not been tampered with.

Tips

- If you cannot change the [ON] or [OFF] state, it is assumed that whether or not a digital signature is always added is specified by the administrator.

Sending by renaming the sender ([Fax Header Settings])

You can use different sender names to send faxes to recipients.

Normally, the default sender name is added. However, you can use different sender names depending as necessary.



Set a fax line type ([Line Setting])

You can set a communication system or protocol and a line type for fax transmission.

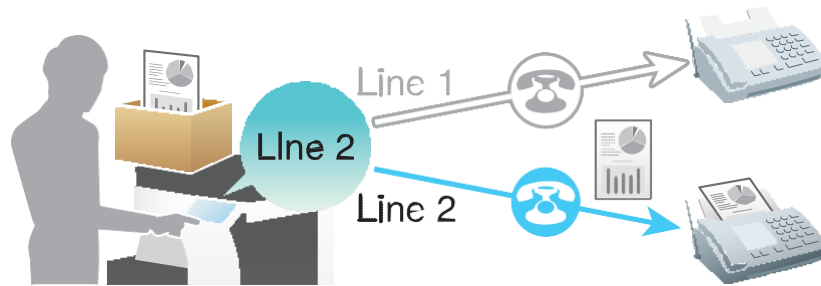

Settings	Description
[TX Method]	<p>Change the communication mode based on the line conditions.</p> <ul style="list-style-type: none"> [Overseas TX]: Select this option to send a fax to areas where communication conditions are poor. Faxes are sent at a lower speed. [ECM]: ECM is an error correction mode defined by ITU-T (International Telecommunication Union - Telecommunication Standardization Sector). Fax machines equipped with the ECM feature communicate with each other, confirming that the sent data is free of errors. This prevents image blurring caused by telephone line noise. The communication time can be reduced by setting ECM to OFF for transmission. However, an image error or communication error may occur depending on the specified communication time value, so change the value to suit conditions. [V.34]: V34 is a communication mode used for super G3 fax communication. When the remote machine or this machine is connected to a telephone line via PBX, however, you may not establish a communication in the super G3 mode depending on telephone line conditions. In this case, it is recommended that you turn the V34 mode off to send data.
[Check Dest. and Send]	<p>Select this option to use the Check Dest. And Send function. The fax number specified for fax is checked against the destination fax number (CSI) and the fax is sent only when they match.</p>

Sending a fax at preset time ([Timer TX])

You can set a time to send the fax.



Settings	Description
[ON]/[OFF]	Select [ON] to specify Timer RX.
[Current Time]	Shows the current time.
[Start Time]	Specify when to start fax transmission using the Keypad . To display the Keypad , tap the input area for the numeral.

Sending a fax with a password ([Password TX])

A fax is sent with a password to a device for which fax destinations are restricted by passwords (that is, the Closed Network RX function is used).

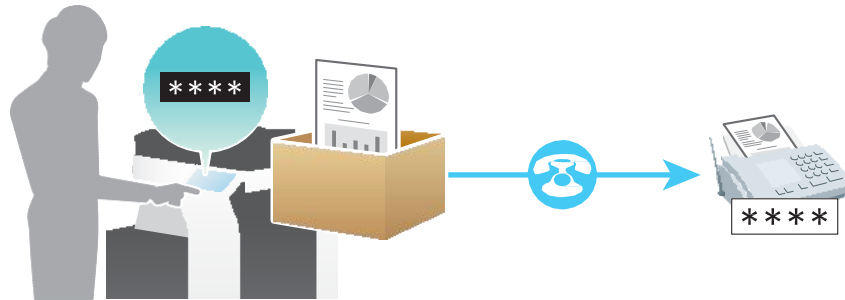

Settings	Description
[ON]/[OFF]	Select [ON] to specify Password TX.
[Password]	Enter the password for Closed Network RX programmed for the destination using the Keypad . To display the Keypad , tap the input area for the numeral.

Sending a fax after specifying a F-code ([F-Code TX])

You can set an F-code for fax and send it to the Relay User Box or the Confidential User Box.

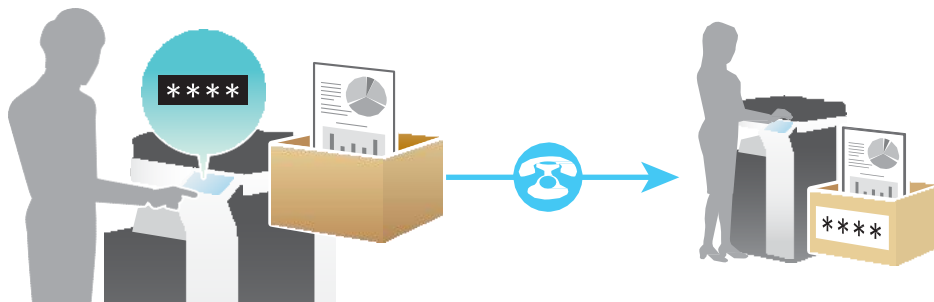

Settings	Description
[ON]/[OFF]	Select [ON] to specify F-Code TX.
[SUB Address]	Enter a SUB address. To display the Keypad , tap the input area for the numeral. <ul style="list-style-type: none"> To use Confidential TX, enter the Confidential User Box number programmed for the destination. To use relay distribution, enter the Relay User Box number programmed for the destination.
[Sender ID]	Enter a sender ID. To display the Keypad , tap the input area for the numeral. <ul style="list-style-type: none"> To use Confidential TX, enter the communication password for Confidential RX that is programmed for the destination. To use relay distribution, enter the Relay User Box password programmed for the destination.



Sindoh
www.sindoh.com